

OPTIMA

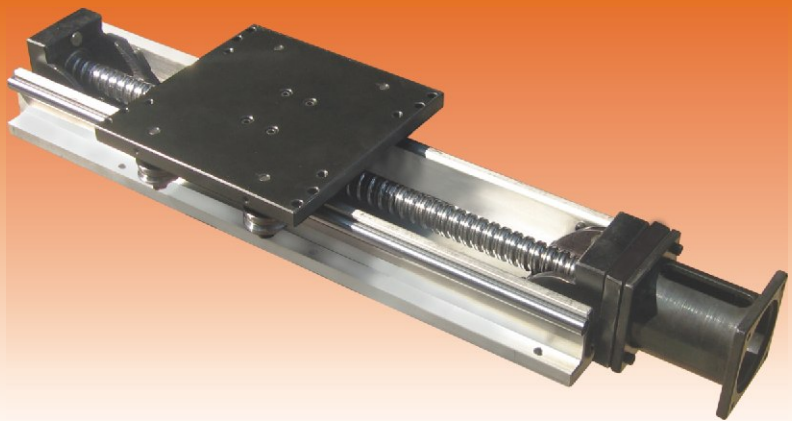
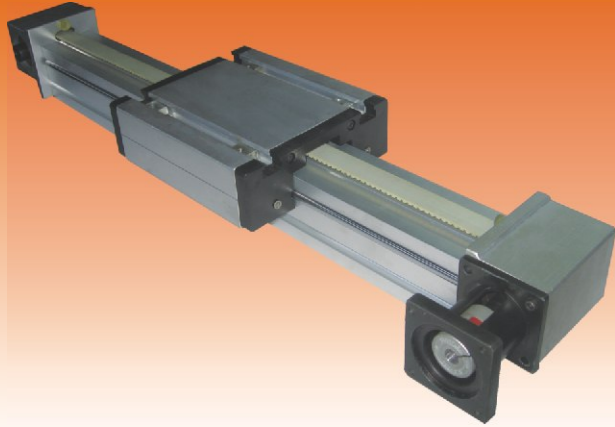

LINEAR MOTION SLIDES

INTRODUCTION

Efficiency in automation can only be attained with simplified processes and systems. To achieve this task, aluminum profile systems and modules suitable for automated applications are available. The simplicity of aluminum profile systems and integrated components ensures functionality and reliability. All the components individually and in sets, are designed and constructed in such a way that they can be assembled without any problem and therefore provide an economical solution.

These systems find excellent solutions for a wide range of automation applications, including packaging equipment, pick and place units, guard door slides, plasma cutting, painting, dispensing, welding, cut off machine and many other industrial machines.

Standard sizes and configuration are available at short notice, but custom solutions can be designed, engineered and manufactured to meet specific requirements.

CONTENTS

Description	Page
● LFR Modules	1 - 11
● LM Slide Units	12 -15
● Cross Roller Guides	16 -19
● Frictionless Slides	20 - 23
● M + V Guides	24
● Spindle Unit	25
● Chamfering Machine	26
● Application Examples	27

LFR MODULES

LINEAR MODULES WITH DRIVE SYSTEMS

Linear guidance system is manufactured using Aluminum extrusions, Precision linear shafts, LFR Track Rollers. The aluminum-extruded profile is stabilized and anodized. Aluminum extrusion forms the main support element, and the hardened steel rods inserted in the raceway forms the guiding surface. Guide rods are induction hardened, ground and hard chrome plated. The complete system is strong, lightweight and compact design. The combined features of the two materials and the relevant working technologies enable the system to be used in many applications as carrying structures.

The features include track rollers life lubrication and continuous lubricated on shafts through oil, felt at both ends of carriage plate.

Linear accuracy can be achieved within 0.100mm and most of the systems have no stroke limitations, maximum stroke up to 50mts in length have been executed so far. These sliding systems can be driven by ball screw, timing belts, rack & pinion, lead screw, pneumatic/hydraulic cylinders, chains, etc. The construction is modular; gantry and bridge construction can be easily achieved for multi axis applications with maximum speed of 2m/s for tooth belt drive and 1 m/s for ball screw.

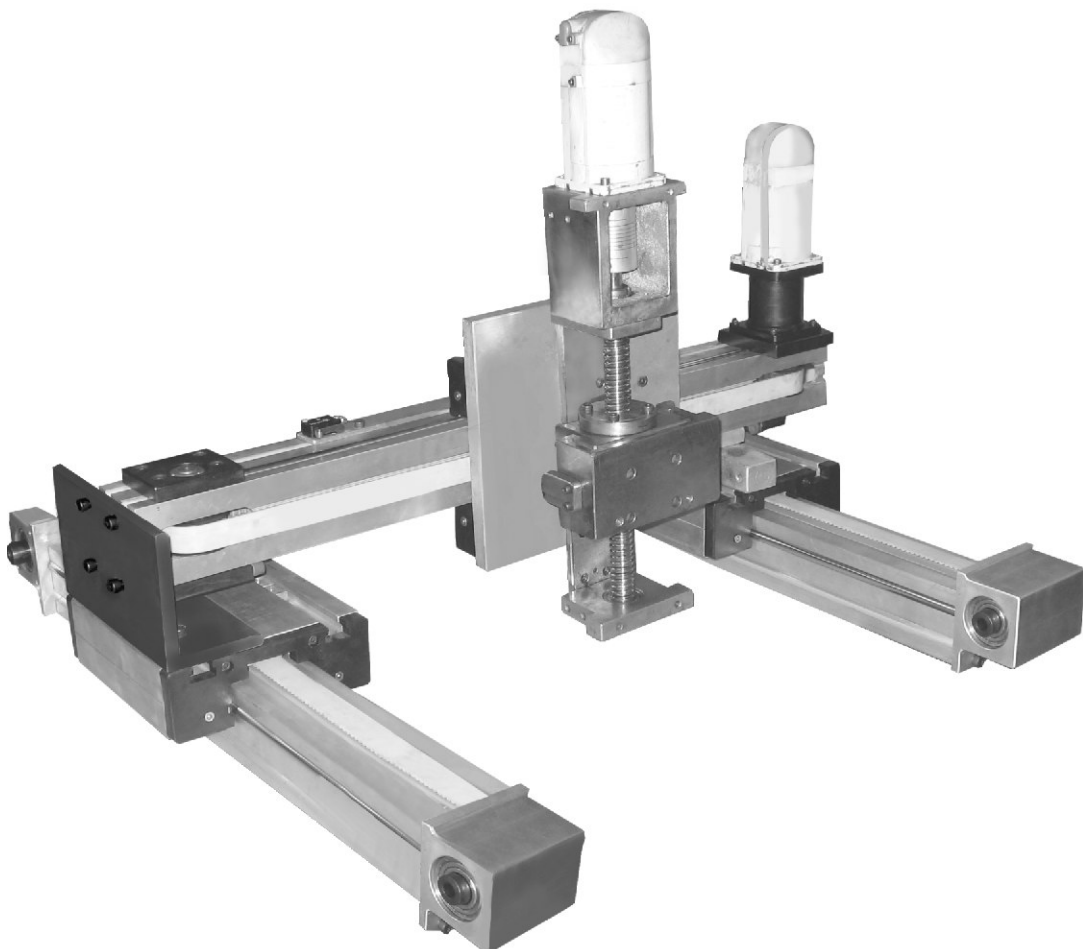

OPTIMA

APPLICATION EXAMPLES

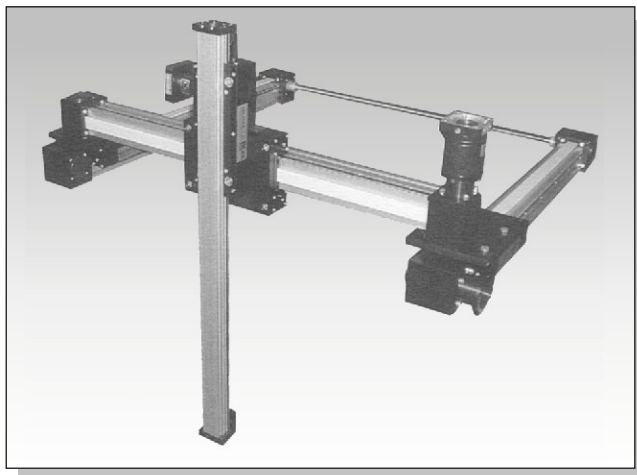

A

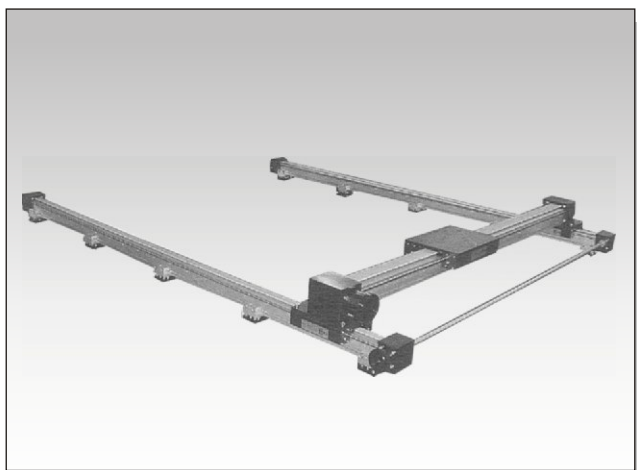
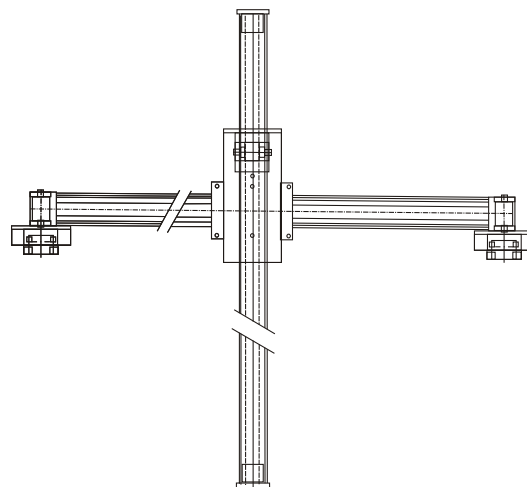

B

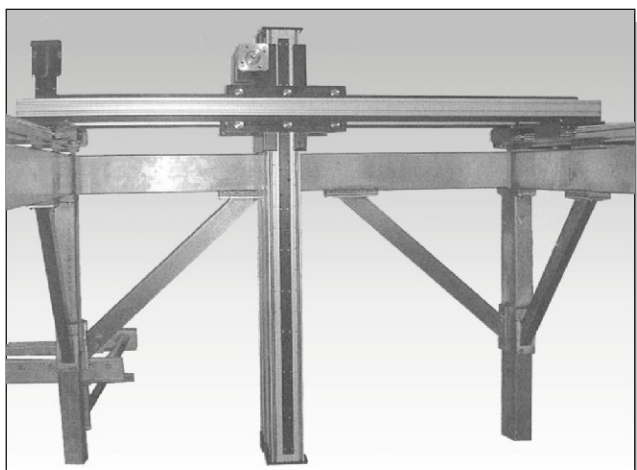
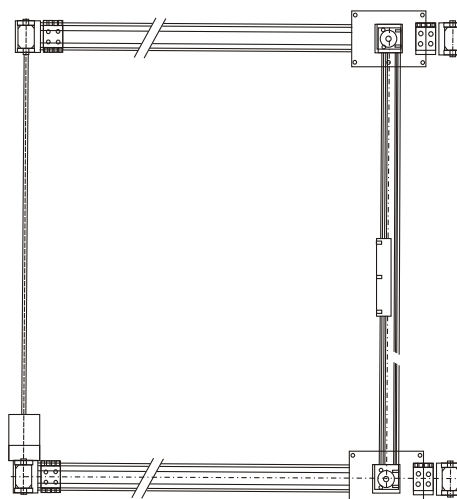

C

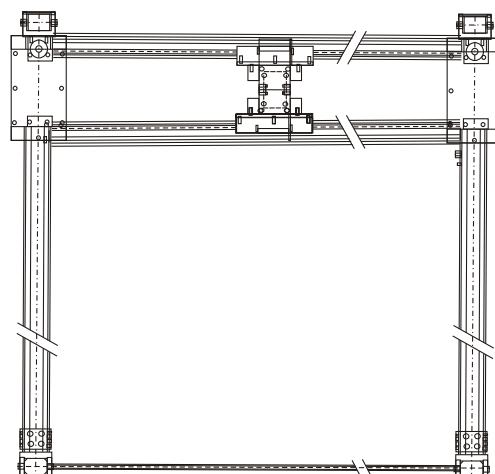

LFI SERIES EXAMPLES

LFI 20 S
Track roller assembly

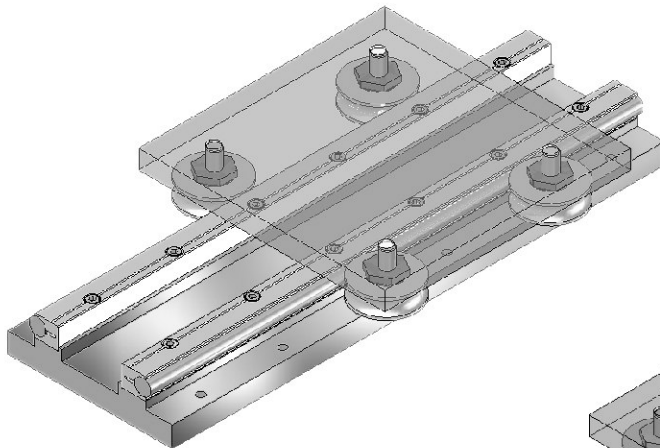

LFI 20 S
Ball screw assembly

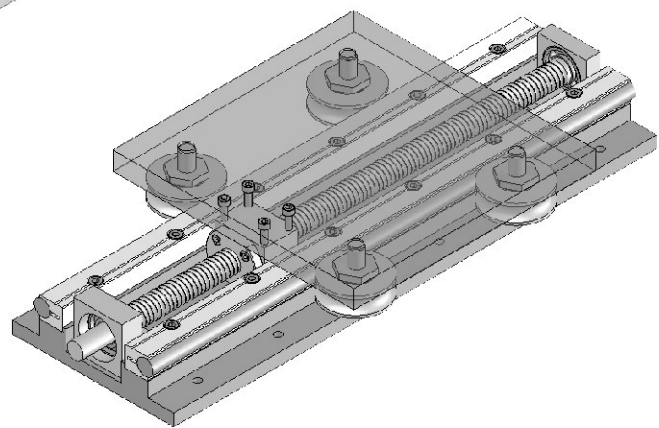

LFI 20 D
Track roller assembly

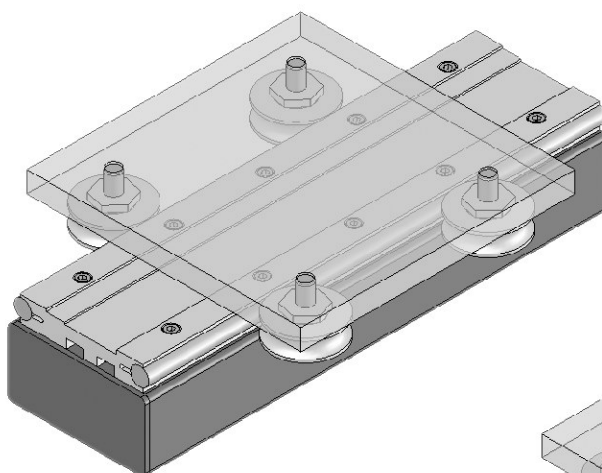

LFI 20 D
Rack & Pinion with
Gear Box Drive

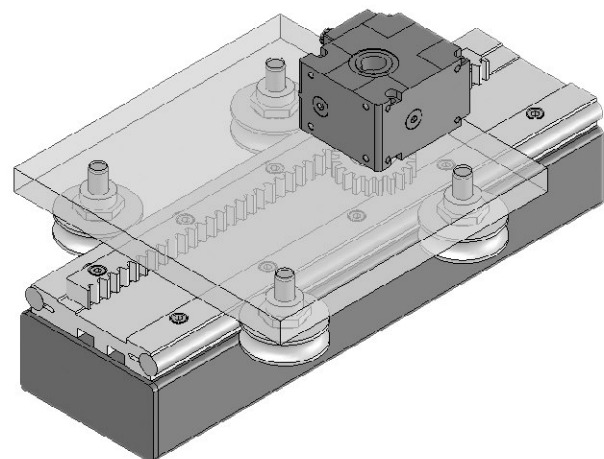

OPTIMA

LFI SERIES - LFI 10 S

LFI 10 S Accessories

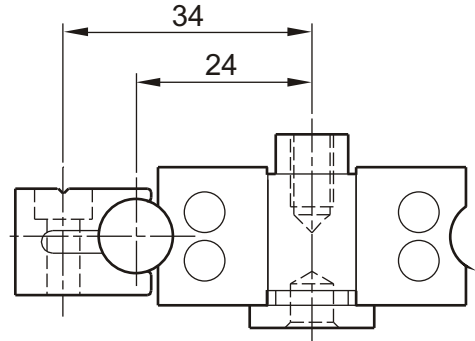

LFI 10 S Assembly

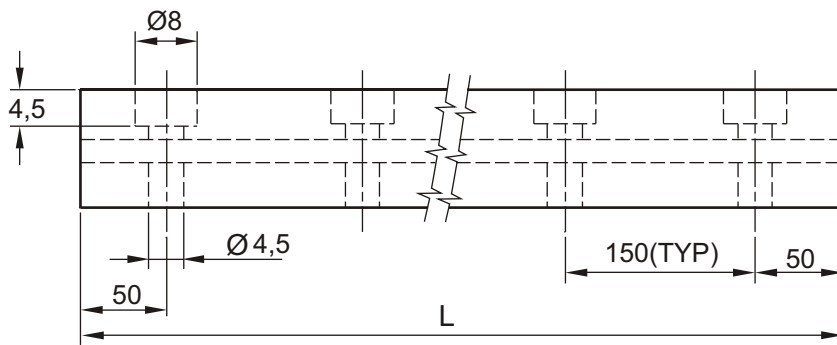

Max. Length in single element = 2000 mm.

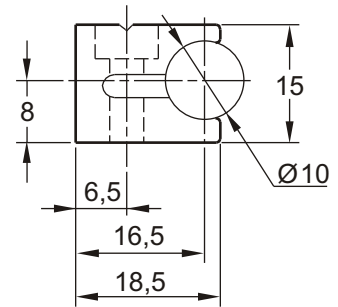

LFI 10 S

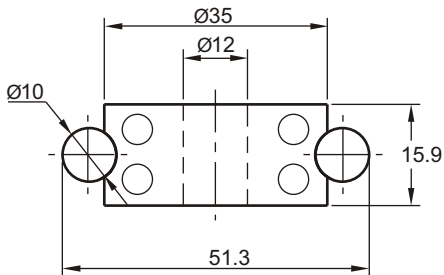
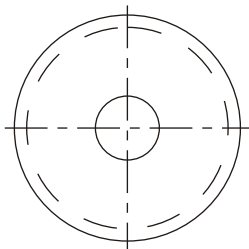

LFR 5201 KDD BEARING

BEARING RATING (KG)	
Dynamic	Static
C	C ₀
1200	710

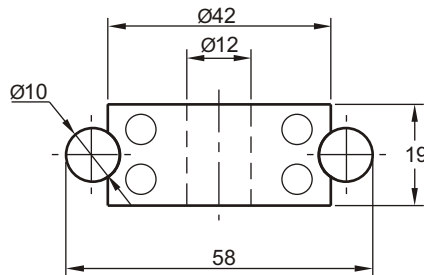
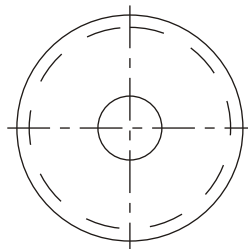

LFR 5301 KDD BEARING

BEARING RATING (KG)	
Dynamic	Static
C	C ₀
1200	710

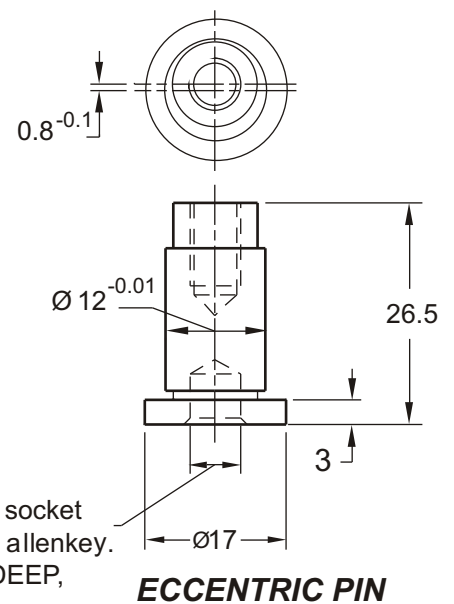

LFI SERIES - LFI 20 D

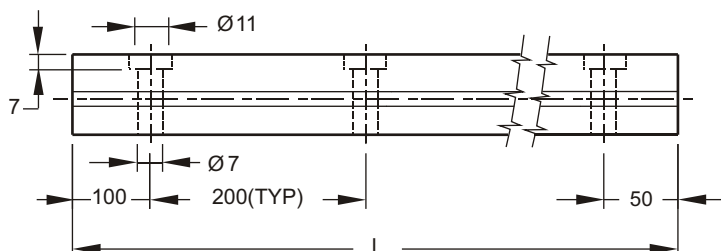
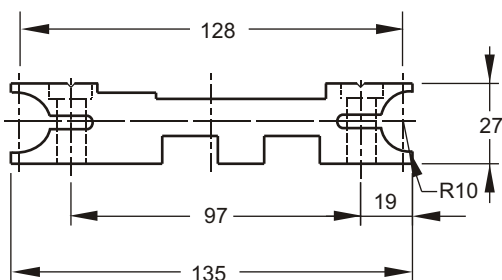
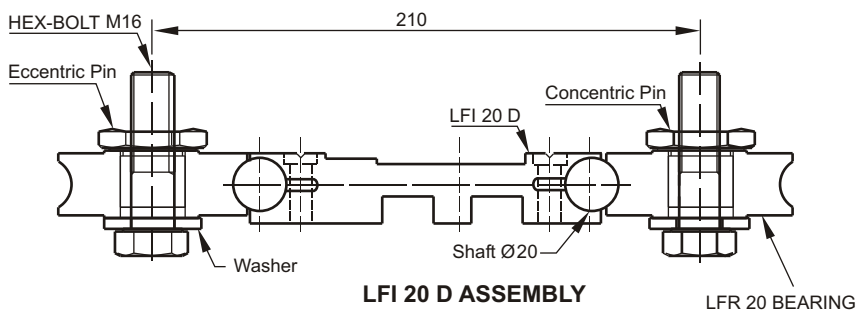
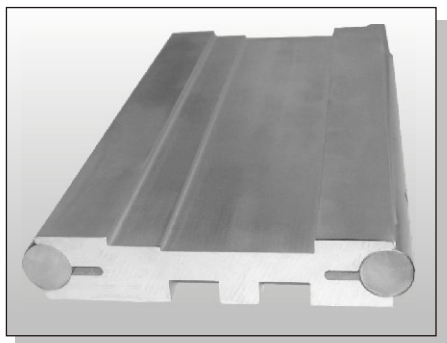

Max. Length in single element = 2500 mm.

- ▶ Longer Rails are supplied in sections with ground butt joints.
- ▶ Available with hard chrome plated shafts.
- ▶ Rails with standard mounting holes and without holes are also available.

LFI SERIES - LFI 20 S

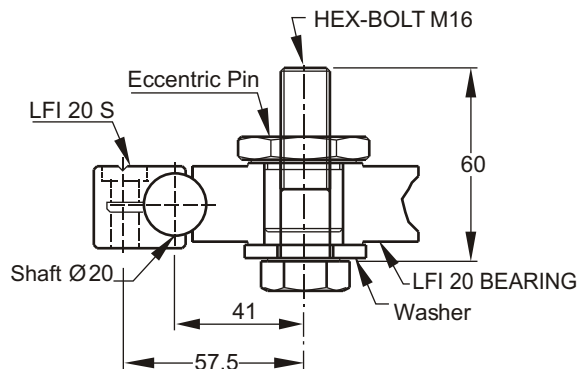

LFI 20 S ASSEMBLY

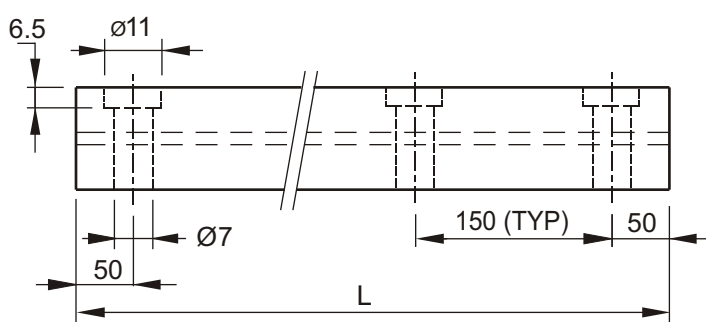

Max. Length in single element = 2000 mm.

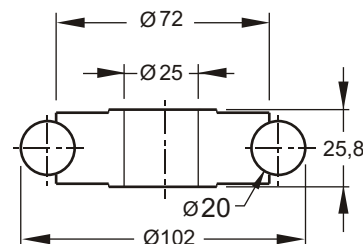
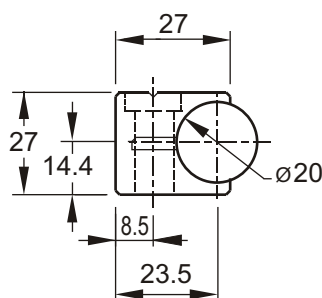

Eccentric Pin

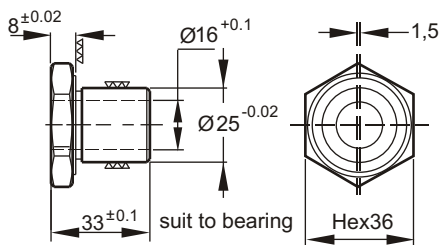

Concentric Pin

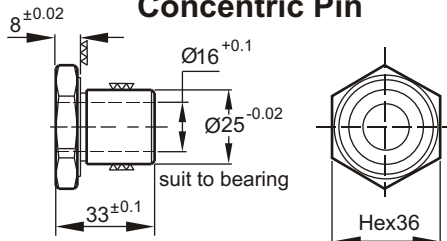

LFI/LFR 20 BEARING

BEARING RATING (KG)	
Dynamic	Static
C	C ₀
2200	1200

OPTIMA

LFR-10 EXTERNAL

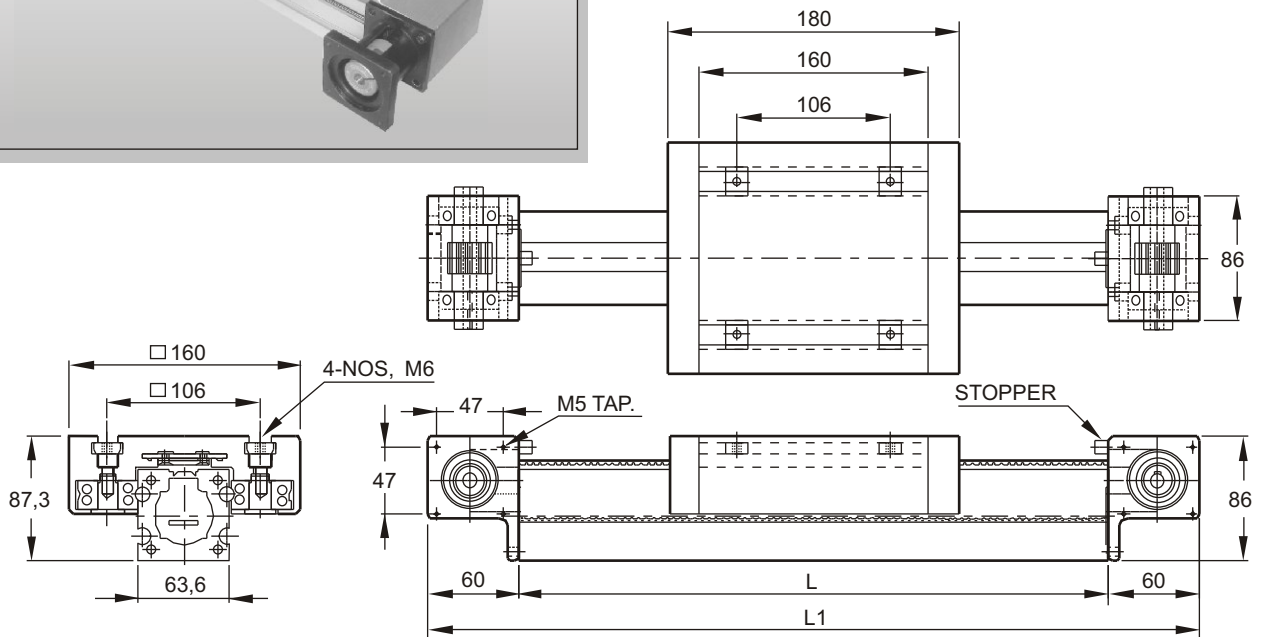
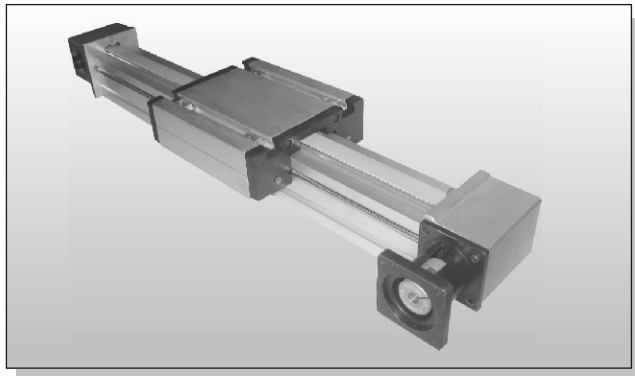

L1=END BLOCK+2 LUBRICATION PLATES+TOP PLATE+END BLOCK+STROKE.

$$L1 = 60 + 20 + 160 + 60 + \text{stroke} =$$

Size	LFR 10						
Forces/torques	state	Fx(Kg)	Fy(Kg)	Fz(Kg)	Mx (Kgm)	My (Kgm)	Mz (Kgm)
		-	200	200	6.7	13	12
Forces/torques	dyn	Fx(Kg)	Fy(Kg)	Fz(Kg)	Mx (Kgm)	My (Kgm)	Mz (Kgm)
		-	200	150	4.3	7.8	12
Speed	(m/sec)max	6					
Area moment of inertia of aluminium profile							
Lx mm ⁴	6,79x10 ⁵						
Ly mm ⁴	6,97 x 10 ⁵						
E-Modul kg/mm ²	7135						

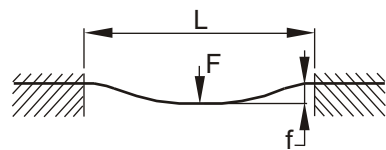
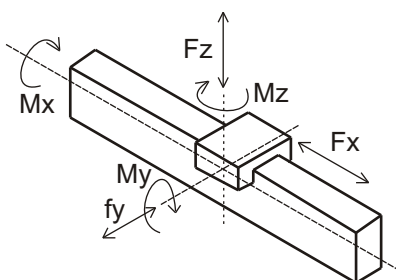

$$f = \frac{F \times L^3}{E \times I \times 192}$$

f=deflection (mm)
 F=load (Kg)
 L=free length (mm)
 E=elastic modulus 7135 (kg/mm²)
 I=second moment of area (mm⁴)

ACCESSORIES

PULLEY

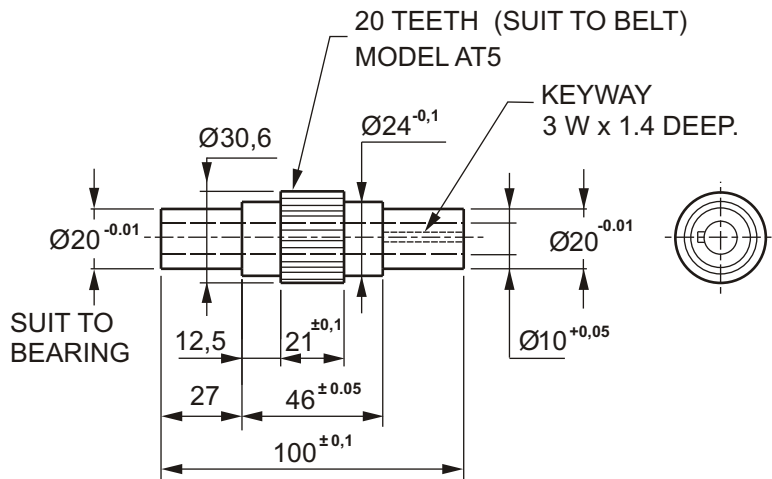

SUPPORT & MOUNTING BLOCKS.

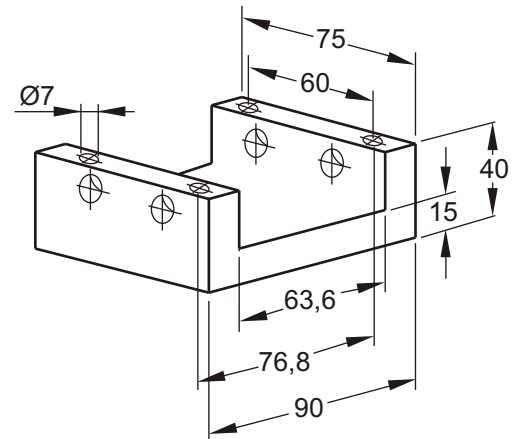

ASSEMBLY PLATE FOR X AND Y AXIS.

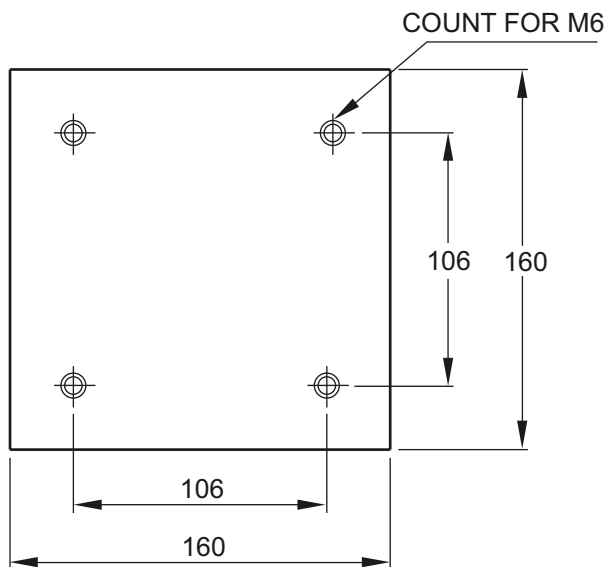

Mat :-Aluminium.
Thickness:-15

HALF ROUND NUT FOR MOUNTING BLOCK.

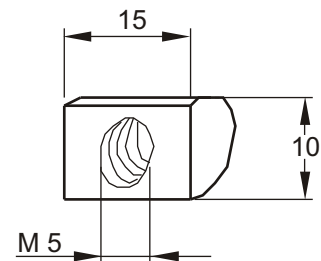
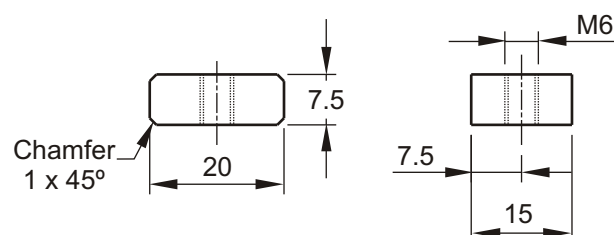
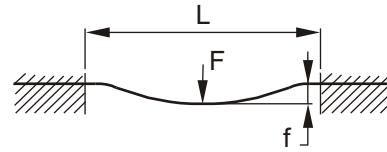
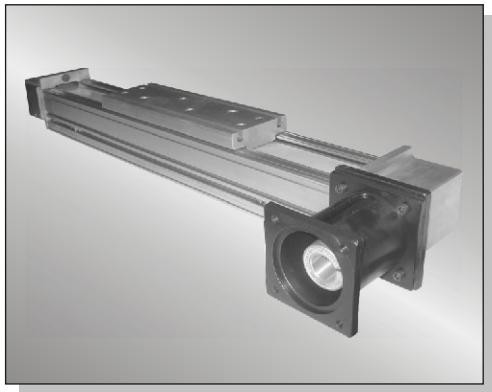

PLATE MOUNTING NUT FOR TOP PLATE



OPTIMA

LFR-10 INTERNAL



$$f = \frac{F \times L^3}{E \times I \times 192}$$

- f=deflection (mm)
- F=load (kg)
- L=free length (mm)
- E=elastic modulus 7135 (kg/mm²)
- I=second moment of area (mm⁴)

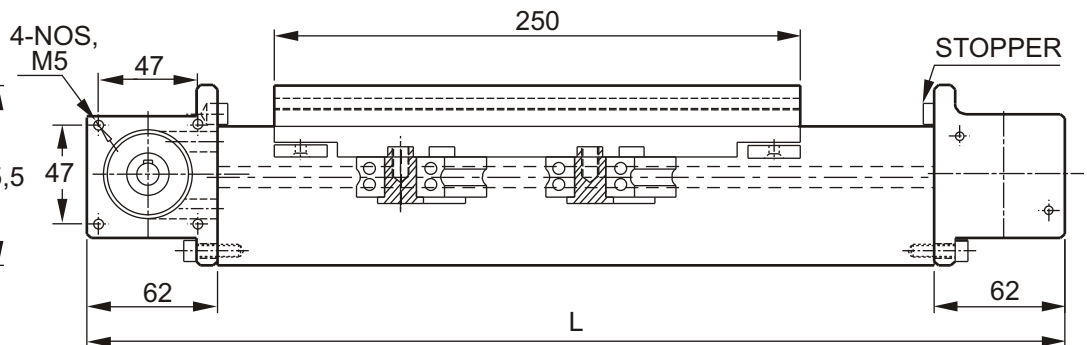
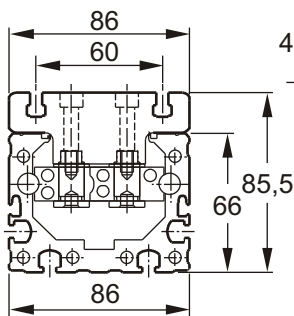
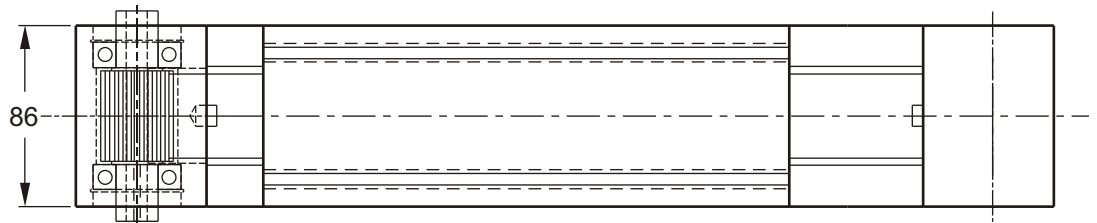
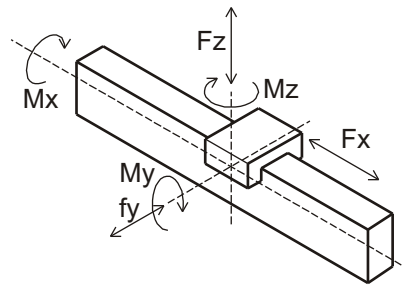

L=END BLOCK+TOP PLATE+STROKE+G.STROKE+END BLOCK

L= 62 + 250 + + 25 + 62

Size	LFR 10						
Forces/torques	state	Fx(kg)	Fy(kg)	Fz(kg)	Mx (kgm)	My (kgm)	Mz (kgm)
		-	204	204	6.7	13	12
Forces/torques	dyn	Fx(kg)	Fy(kg)	Fz(kg)	Mx (kgm)	My (kgm)	Mz (kgm)
		-	204	153	4.3	7.8	12
Speed	(m/sec)max	6					
	Area moment of inertia of aluminium profile						
Lx mm ⁴	6,79x10 ⁵						
Ly mm ⁴	6,97x10 ⁵						
E-Modul N/mm ²	7135						

ACCESSORIES

Mounting from above

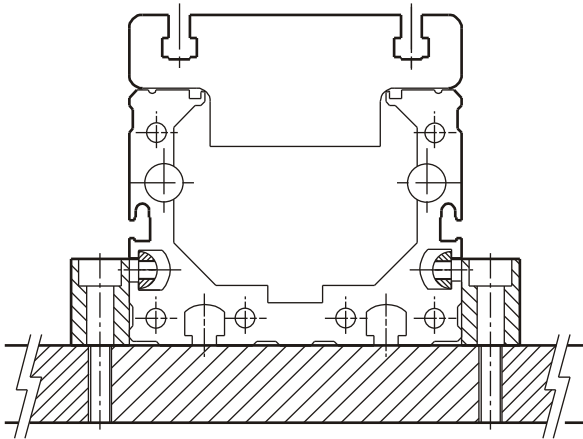

Mounting from below

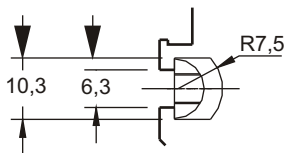
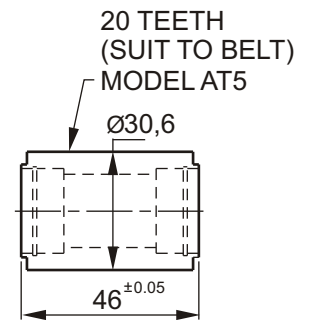
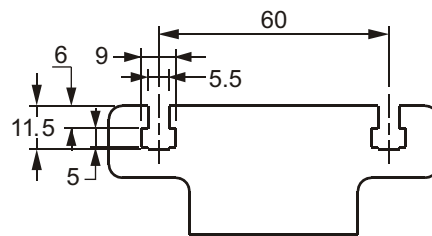
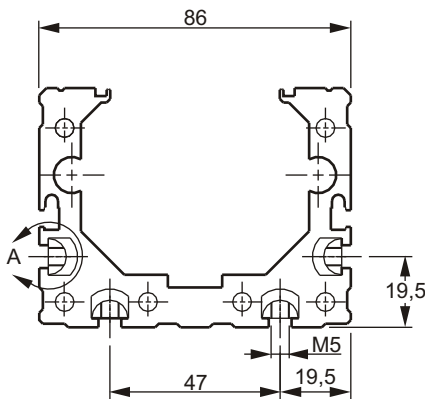
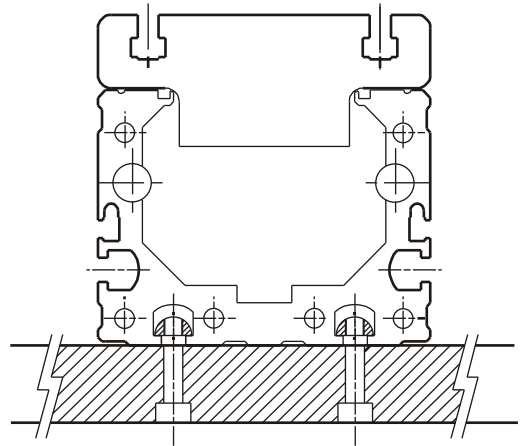

Detail : A

PULLEY.

20 TEETH (SUIT TO BELT)
MODEL AT5

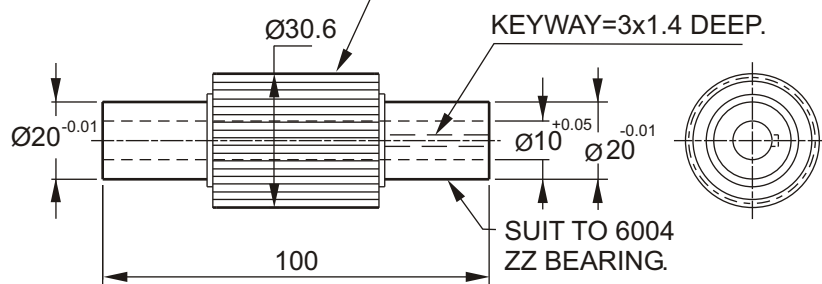

OPTIMA

LFR-20

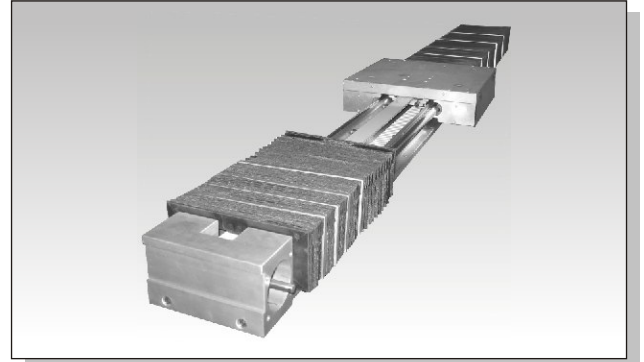
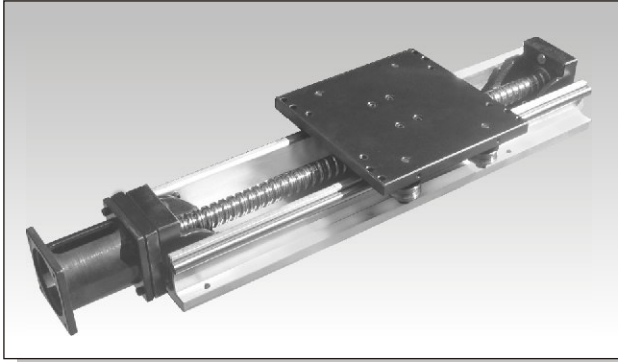

LFR20 BALLSCREW.

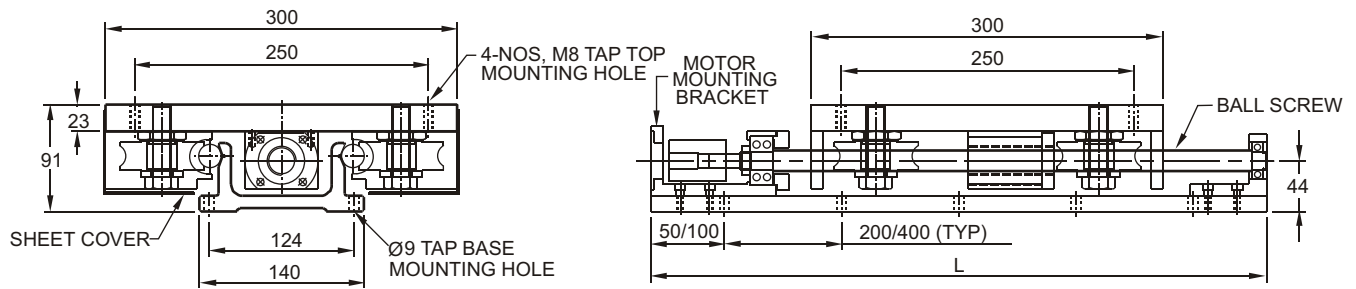
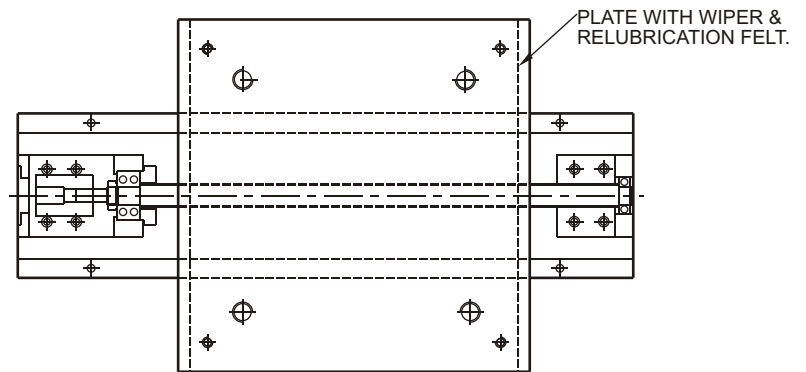

LFR20 TIMER BELT.

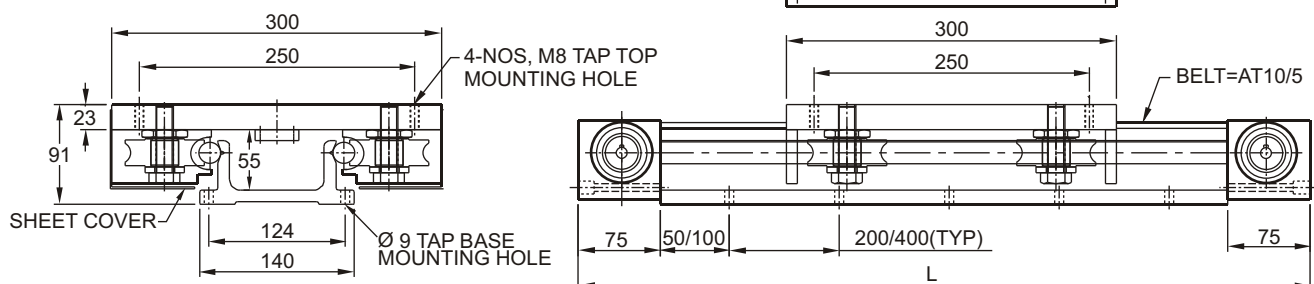
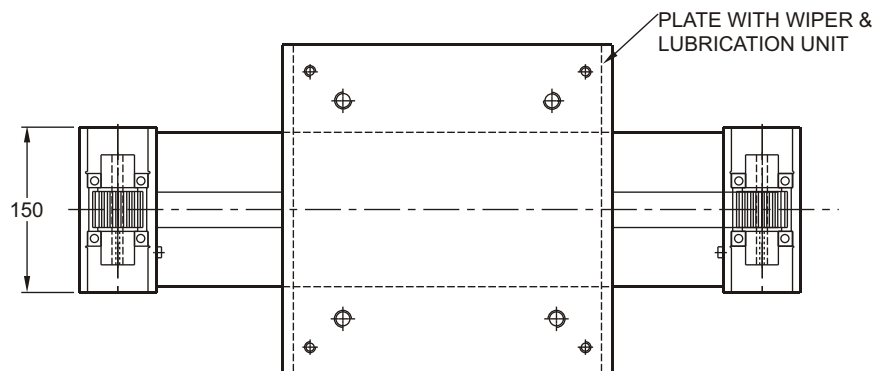

ACCESSORIES

NUT HOUSING

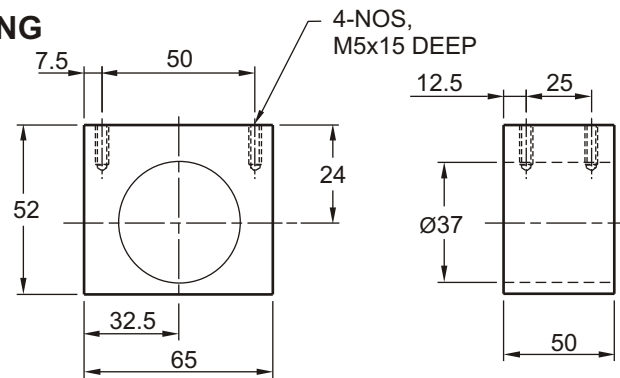

4-NOS,
M5x15 DEEP

NOTE=HOUSING FOR 2005 /2010 BALLSCREW NUT

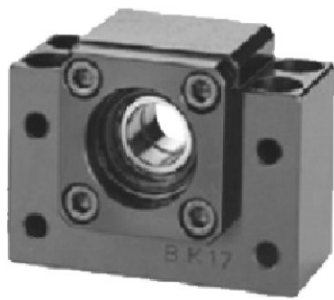

**Ball Screw
Support Unit BK Type**

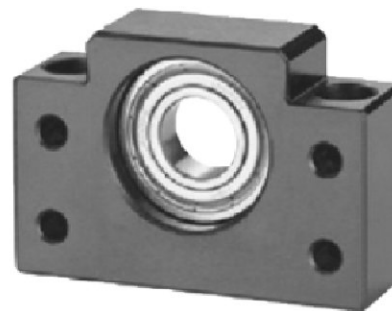

**Ball Screw
Support Unit BF Type**

PULLEY

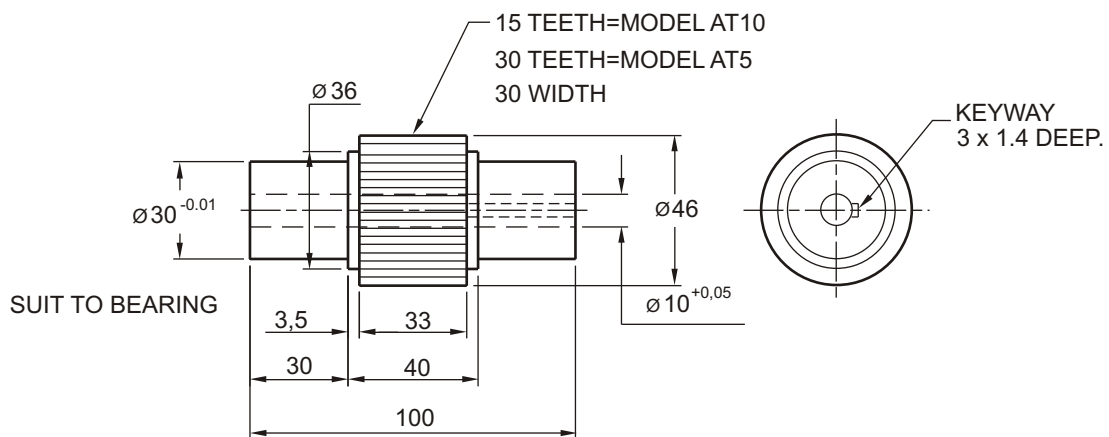

SUIT TO BEARING

OPTIMA

LM SLIDE UNIT- TYPE KK

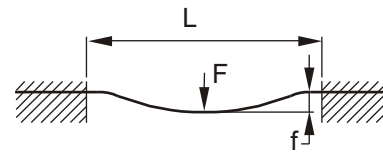
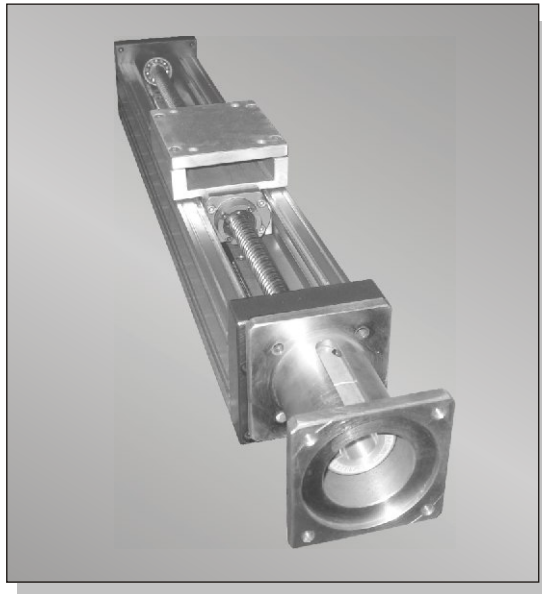

$$f = \frac{F \times L^3}{E \times I \times 192}$$

f=deflection (mm)
 F=load (kg)
 L=free length (mm)
 E=elastic modulus 7135 (kg/mm²)
 I=second moment of area (mm⁴)

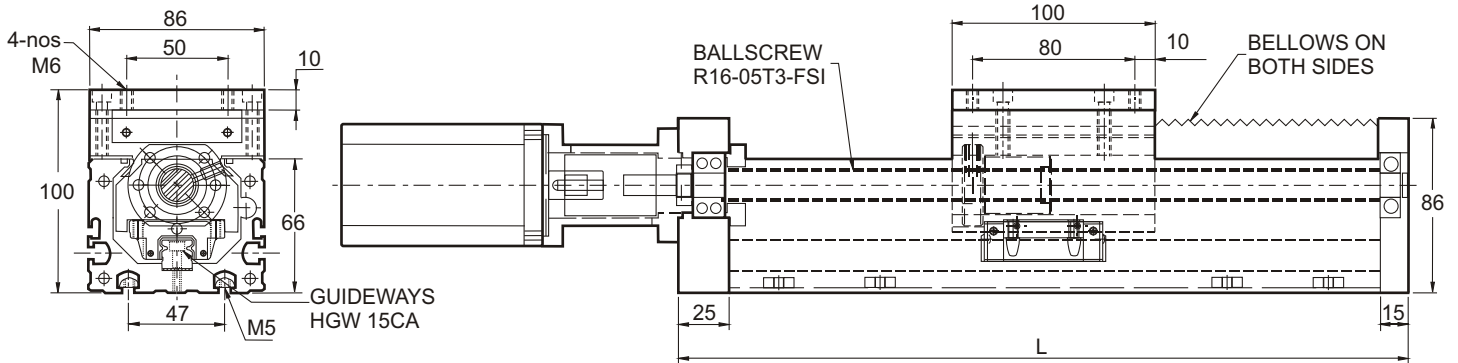
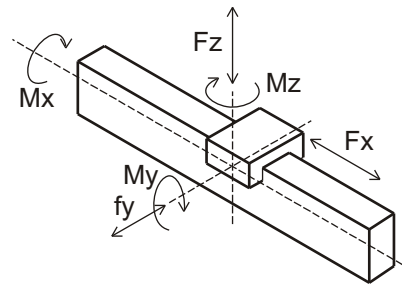

TOTAL LENGTH=END PLATE + STROKE + TOP PLATE + END PLATE + BELLOWS

$$L = 25 + \quad + \quad 100 + 15 +$$

Size	KK SLIDE						
Basic static Load Rating Co (kg)	25.31	Fx(kg)	Fy(kg)	Fz(kg)	Mx (kgm)	My (kgm)	Mz (kgm)
		-	-	-	170	150	150
Basic Dynamic Load Rating C (kgf)	11.38	Weight		Block (kg)	0.17	Rail (kg/m)	1.45
Speed	(m/sec)max	3					
	Area moment of inertia of aluminium profile						
Lx mm ⁴	6,79x10 ⁵						
Ly mm ⁴	6,97x10 ⁵						
E-Modul kg/mm ²	7135						

LM SLIDE UNIT - TYPE LMX

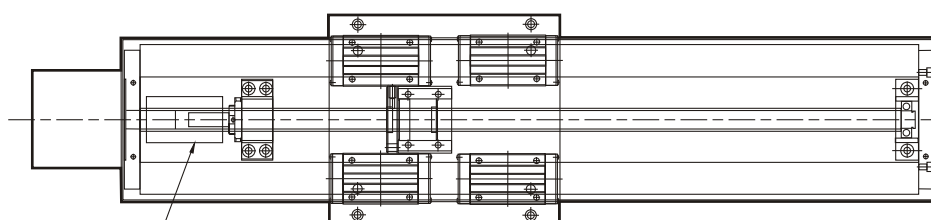
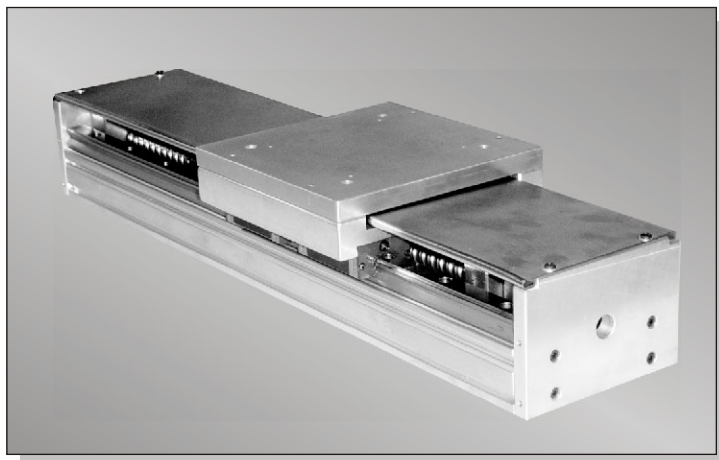

ALS-040-Y
(CLAMPING TYPE)
COUPLING

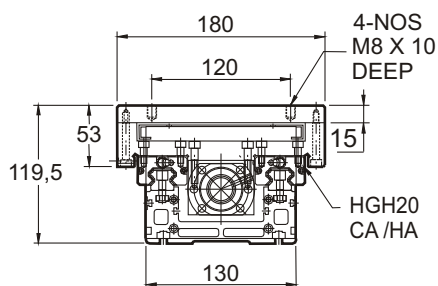

4-NOS
M8 X 10
DEEP
HGH20
CA/HA

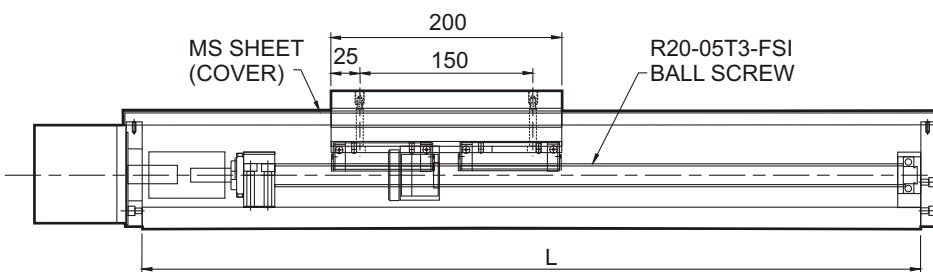

MS SHEET
(COVER)

R20-05T3-FSI
BALL SCREW

TOTAL LENGTH=1st END PLATE + STROKE + TOP PLATE + 2nd END PLATE + SAFETY

$$L = 120 + \text{STROKE} + 200 + 20 + 15$$

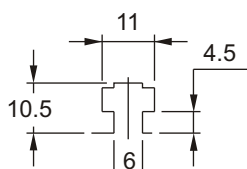

DETAIL A
SCALE 2:1

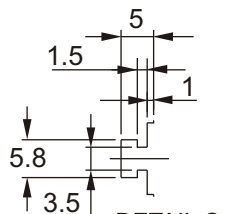

DETAIL C
SCALE 2:1

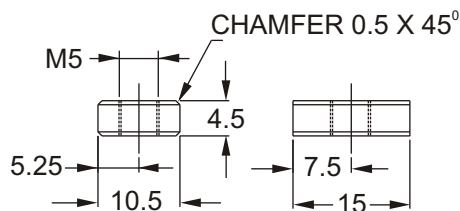
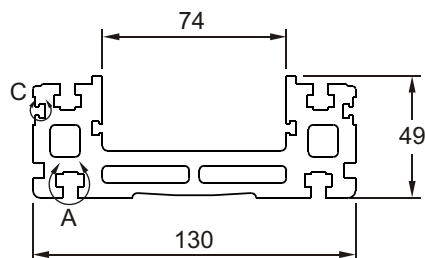

T - NUT

Linear Guide Wages	Basic Dynamic load rating	Basic Static load rating
	C (KN)	C ₀ (KN)
HGH 20CA	17.75	37.84
HGH 20HA	21.18	48.84

OPTIMA

LM SLIDE UNIT - TYPE LMX

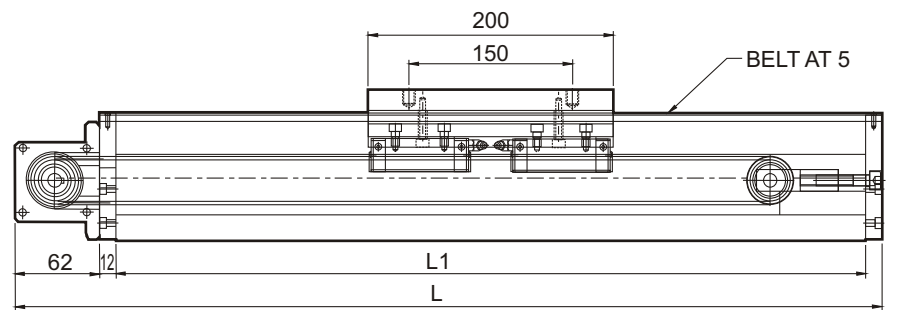
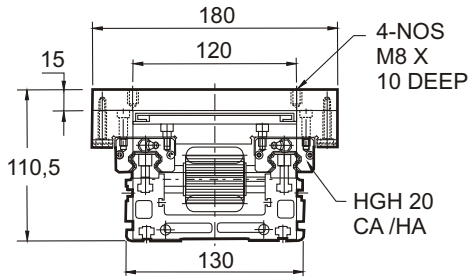
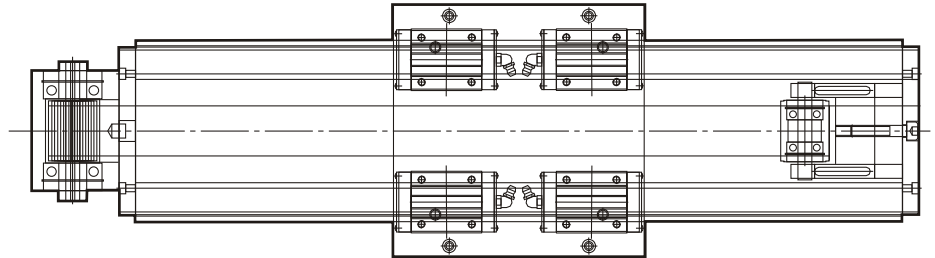
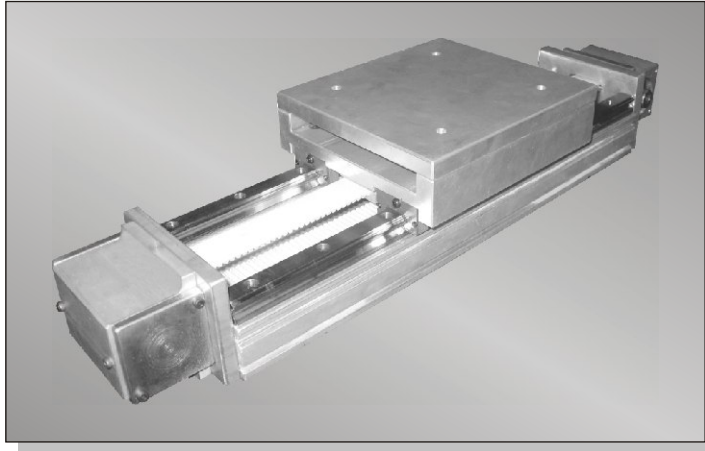

Total L = Motor Pulley End + 1st Cover End + Stroke + Top Plate + Pulley End + 2st Cover End + Safety

$$L = 62 + 12 + \text{Stroke} + 200 + 100 + 12 + 15$$

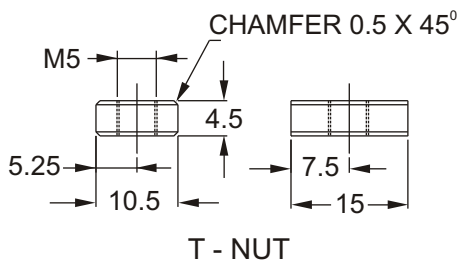
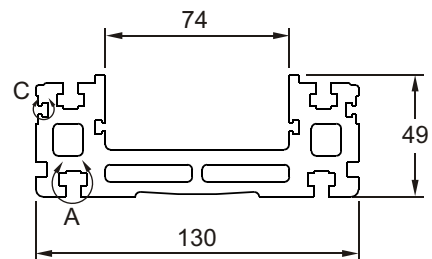
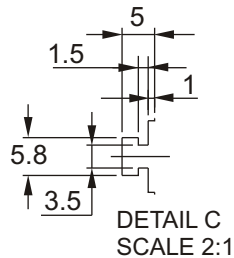
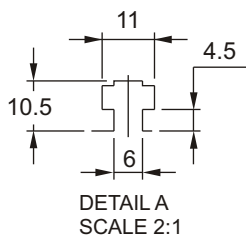

Linear Guide Wages	Basic Dynamic load rating	Basic Static load rating
	C (KN)	C ₀ (KN)
HGH 20CA	17.75	37.84
HGH 20HA	21.18	48.84

LM SLIDE UNITS

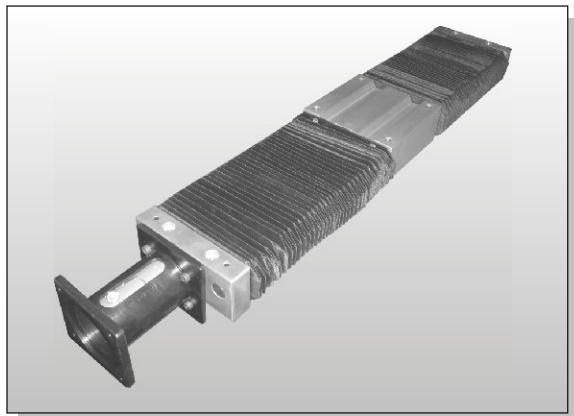

Detail Y2:1

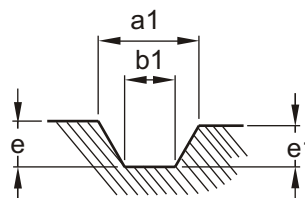

Detail X4:1

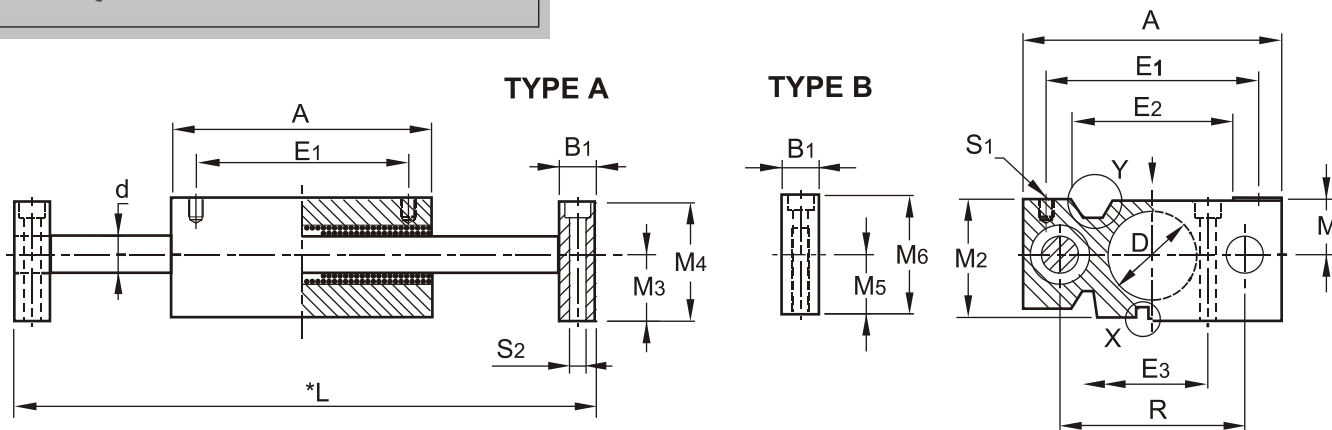
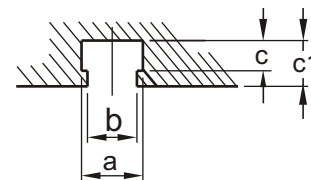

LINEAR MOTION SLIDE UNIT CLOSED MODEL WITHOUT DRIVE UNIT

STRUCTURAL DESIGN

The assembly consists of :

- The housing (aluminium alloy extruded)
- Four ball bushings
- Two end blocks (aluminium alloy/cast iron)
- Two Hardened Precision Steel Shafts, g6 tolerance.

End block type A

For applications with end blocks bolted in place and travelling centre housing block.

End block type B.

For applications with centre housing block bolted in place and travelling end blocks. Precision steel shafts can be machined to customer's specification and are available in any desired length. The slide units are delivered assembled.

Before machining the housing block in any way, protect the ball bushing to prevent entry of cutting chips.

Ordering example

LM Slide, Shaft Dia 20 & Stroke 1200 mm.

Ref:- LMC 20 - Stroke 1200

MODEL & SHAFT DIA d	DIMENSIONS																				LOAD CAP (kg)				
	A	M	M2	R	E1	E2	E3	B1	S1	S2	M3	M4	M5	M6	D	a	b	c	c1	a1	b1	e	e1	C	Co
LMC 12	88	21	42	56	68	48	28	14	M 6	7	23	42	20	42	24	6.7	5.4	3.3	5	15	7.5	7	6	130	190
LMC 16	124	26	55	90	100	77	55	18			31	55	27.5	55	38					21.5	10.5	10	9	250	380
LMC 20	140	30	64	100	115	87	60	20	M 8	9	36	64	32	64	48					22	11	280	440		

* L = As per Customer request.

CROSS ROLLER GUIDES

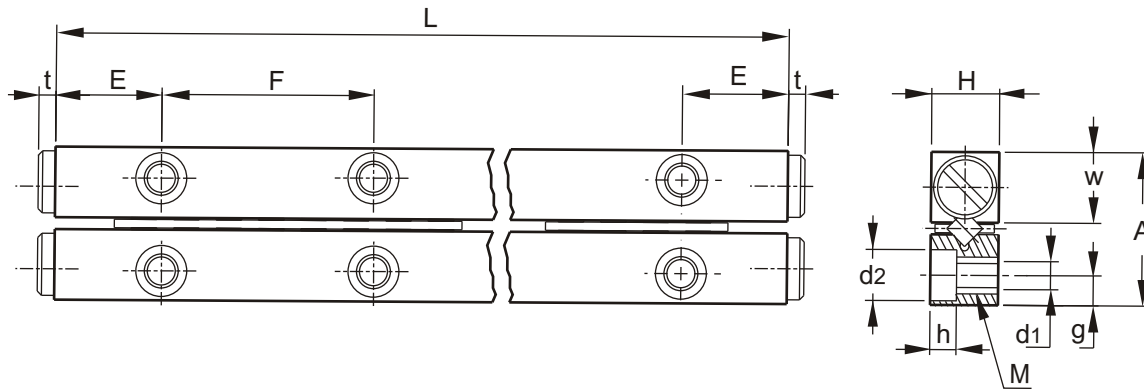
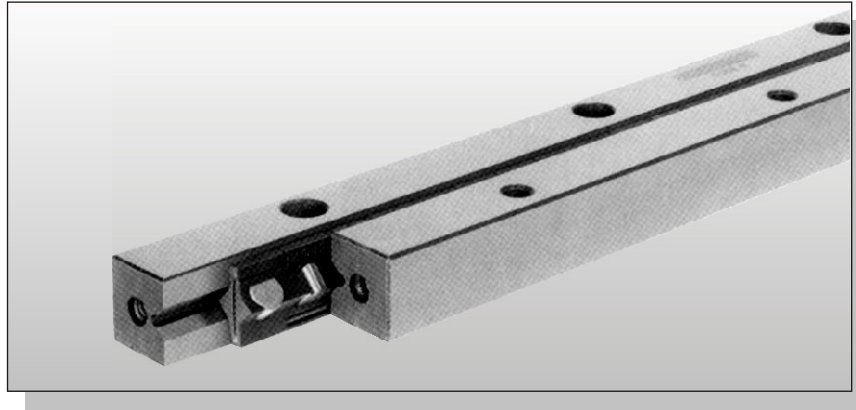

Model No.	Roller diameter (ball diameter) Da	Main dimensions											Mass (Ref)			
		A	H	W	g	M	d1	d2	h	R	Length L [Number of rollers per roller cage (Z)]	F	E	Way ⁽¹⁾ kg/m	Roller Cage ⁽²⁾ g	t
R 3	3	18	8	8.3	3.5	M4	3.3	6	3.1	(1) 42, (2) 62, (3) 82, (4) 102, (5) 122 (6) 142, (7) 162, (8) 182, (9) 202, (10) 222, (11) 242	(1) 50(8), (2) 75(12), (3) 100(16), (4) 125(20), (5) 150(24) (6) 175(28), (7) 200(32), (8) 225(36), (9) 250(40), (10) 275(44), (11) 300(48)	25	12.5	0.5	2.96	2
R 4	4	22	11	10	4.5	M5	4.3	7.5	4.1	(1) 73, (2) 101, (3) 136, (4) 164, (5) 199, (6) 227, (7) 262, (8) 297, (9) 325, (10) 360, (11) 388	(1) 80(10), (2) 120(14), (3) 160(19), (4) 200(23), (5) 240(28), (6) 280(32), (7) 320(37), (8) 360(42), (9) 400(46), (10) 440(51), (11) 480(55)	40	20	0.82	6.91	
R 6	6	31	15	14	6	M6	5.3	9.5	5.2	(1) 84, (2) 129, (3) 165, (4) 210, (5) 246, (6) 282, (7) 327, (8) 363, (9) 408, (10) 444, (11) 489.	(1) 100(9), (2) 150(14), (3) 200(18), (4) 250(23), (5) 300(27), (6) 350(31), (7) 400(36), (8) 450(40), (9) 500(45), (10) 550(49), (11) 600(54).	50	25	1.57	20.3	3
R 9	9	44	22	20.2	9	M8	6.8	10.5	6.2	(1) 173, (2) 257, (3) 327, (4) 411, (5) 495, (6) 565, (7) 649, (8) 733, (9) 817, (10) 887, (11) 971.	(1) 200(9), (2) 300(14), (3) 400(18), (4) 500(23), (5) 600(27), (6) 700(31), (7) 800(36), (8) 900(40), (9) 1000(45), (10) 1100(49), (11) 1200(54).	100	50	3.3	64.8	
R 12	12	58	28	26.9	12	M10	8.5	13.5	8.2	(1) 168, (2) 258, (3) 330, (4) 420, (5) 492, (6) 564, (7) 654, (8) 726, (9) 816, (10) 888, (11) 978	(1) 200(9), (2) 300(14), (3) 400(18), (4) 500(23), (5) 600(27), (6) 700(31), (7) 800(36), (8) 900(40), (9) 1000(45), (10) 1100(49), (11) 1200(54)			5.57	9.46	

Note:- The values in brackets for the dimension A show the dimensions for combination with the Ball cage type B.

⁽¹⁾ This value shows mass per one meter for individual way.

⁽²⁾ This value shows mass of one roller cage in which ten rollers are incorporated.

CROSS ROLLER GUIDES

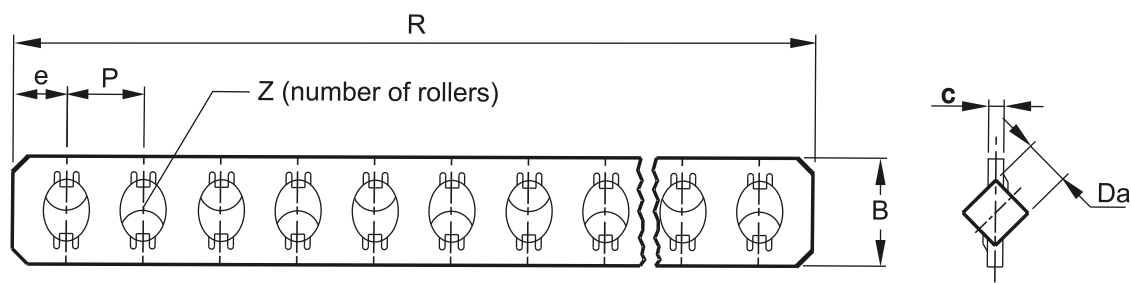

Model No.	Main dimensions					Basic load rating (for one roller)		Permissible preload amount
	D_a	c	B	P	e	C kg	Co_z kg	Mm
R 3	3	0.3	7	5	3.5	37	28	-4
R 4	4		10.5	7	5	78	65	-5
R 6	6	0.6	13.5	9	6	195	180	-7
R 9	9	1	19	14	9.5	440	445	-10
R 12	12		25	18	12	740	780	-13

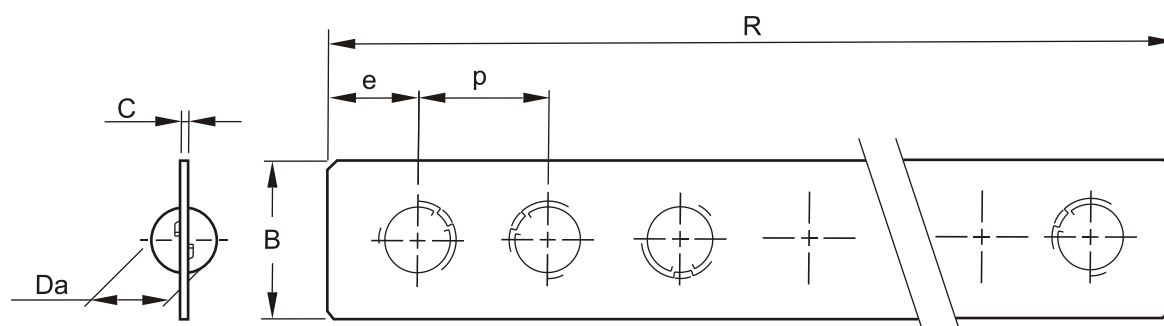

Model No.	Main dimensions					Basic load rating (for one ball)	
	D_a	C	B	P	e	C kg	Co kg
B 3	3	0.8	7	6	4.5	2.8	8.9
B 4	4	0.4	10.5	7		4.6	15.8
B 6	6	0.6	13.5	10	6	10	36
B 9	9.525	1	19	14	8.5	22	80
B 12	11.906		25	20	12.5	33	145

CROSS ROLLER GUIDES

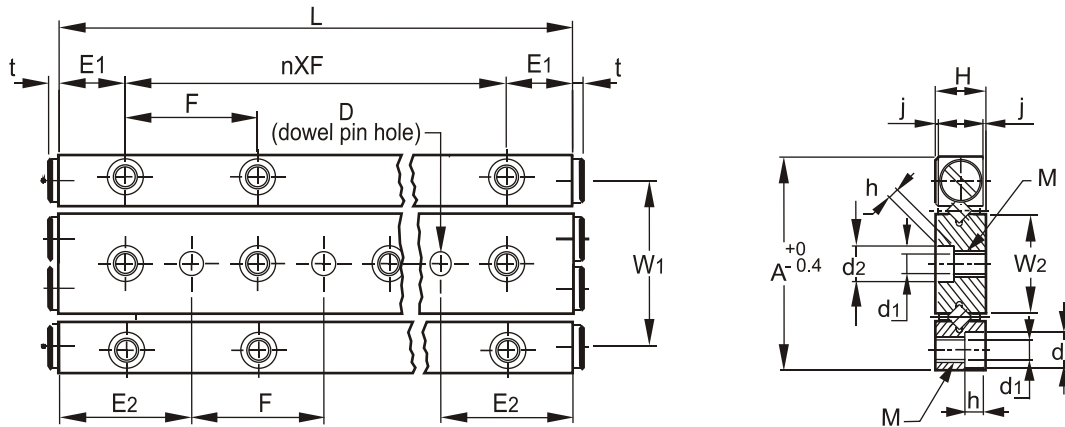

Model number	Weight		Boundary dimensions				Nominal dimensions Roller cage dimensions				
	Way (1) kg/m	Roller cage (2) g	A	H	L (n x F)	j	Da	R	Z	P	
WRT 3 - 50	1.99	2.96	36	8.5	50 (1X25)	0.5	3	42	8	5	3.5
WRT 3 - 75					75 (2X25)			62	12		
WRT 3 - 100					100 (3X25)			82	16		
WRT 3 - 125					125 (4X25)			102	20		
WRT 3 - 150					150 (5X25)			122	24		
WRT 3 - 175					175 (6X25)			142	28		
WRT 3 - 200					200 (7X25)			162	32		
WRT 3 - 225					225 (8X25)			182	36		
WRT 3 - 250					250 (9X25)			202	40		
WRT 3 - 275					275 (10X 25)			222	44		
WRT 3 - 300					300 (11X25)			242	48		
WRT 4 - 80	3.28	6.91	44	11.5	80 (1X40)	0.5	4	73	10	7	5
WRT 4 - 120					120 (2X40)			101	14		
WRT 4 - 160					160 (3X40)			136	19		
WRT 4 - 200					200 (4X40)			164	23		
WRT 4 - 240					240 (5X40)			199	28		
WRT 4 - 280					280 (6X40)			227	32		
WRT 4 - 320					320 (7X40)			262	37		
WRT 4 - 360					360 (8X40)			297	42		
WRT 4 - 400					400 (9X40)			325	46		
WRT 4 - 440					440 (10X40)			360	51		
WRT 4 - 480					480 (11X40)			388	55		

CROSS ROLLER GUIDES

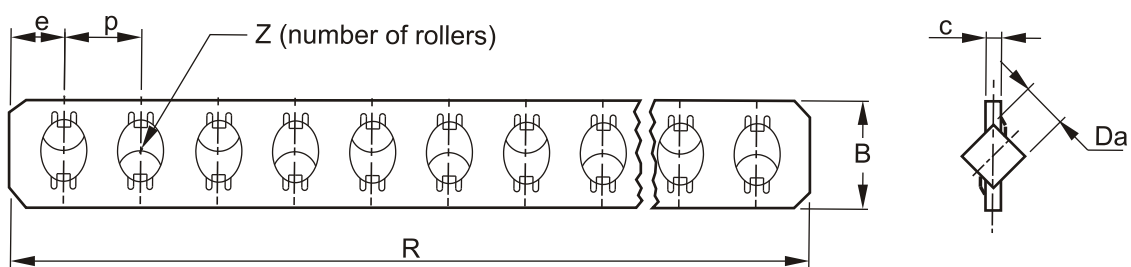

Mounting dimensions										Basic dynamic load rating C ⁽³⁾ kg	Basic static load rating Co ⁽³⁾ kg	Allowable load Fu ⁽³⁾ kg
W ₁	W ₂	E ₁	E ₂	M	d ₁	d ₂	h	D Tolerance	t			
29	16.6	12.5	25	M4	3.3	6	3.1	4 +0.0120 0.0000	2	68	62	21
35	20	20	40	M5	4.3	7.5	4.1	5 +0.0120 0.0000		130	120	40

FRICTIONLESS TABLES

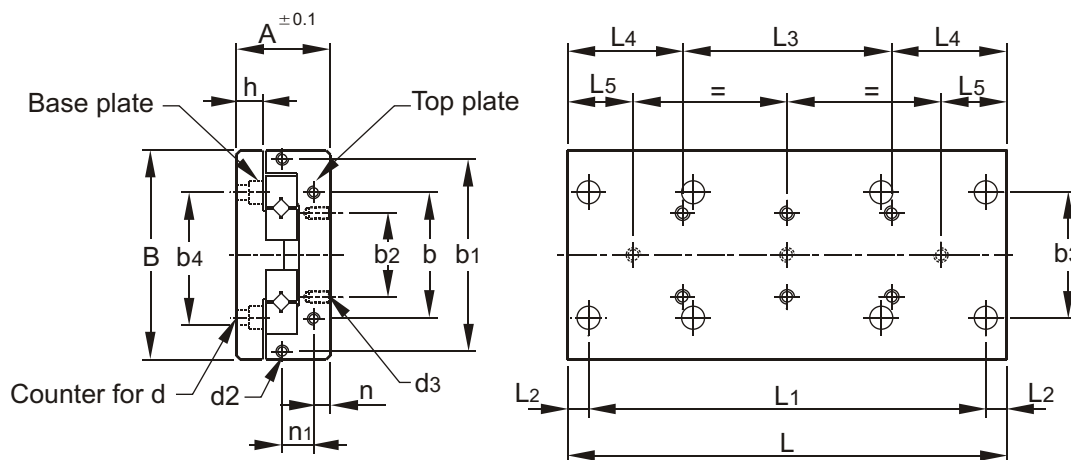

FRICTIONLESS TABLES

Frictionless tables offer designers additional flexibility in their choice of ready to install components for precision linear motion. The crossed roller slides, when compared to other products of equal size, offer higher load carrying capacity & when operating at high cycle rates or with shock and over hanging

load, improved performance. Most importantly, the frictionless tables provide high accuracy and repeatability. Their overall performance is better than ball slides especially in applications where loads must be moved in compact assemblies. Further these slides can be made light weight using aluminium carriage and aluminium base.

Model No.	A	B	Stroke S	n1	n	L	L1	L2	L3	L4	L5
NK3 - 55	28	60 ^{+0.1} _{-0.4}	30	-	5.5	55	1x25	15	-	27.5	5.5
NK3 - 80			45			80	2x25		10.5		
NK3 - 105			60			105	3x25		15.5		
NK3 - 130			75			130	4x25		20.5		
NK3 - 155			90			155	5x25		25.5		
NK3 - 180			105			180	6x25		30.5		
NK3 - 205			130			205	7x25		30.5		
NK6 - 110	45	100 ^{+0.2}	60	15	8	110	1x50	30	-	55	16.5
NK6 - 160			95			160	2x50		24		
NK6 - 210			130			210	3x50		31.5		
NK6 - 260			165			260	4x50		39		
NK6 - 310			200			310	5x50		46.5		
NK6 - 360			235			360	6x50		54		
NK6 - 410			265			410	7x50		64		
NK9 - 210	60	145 ^{+0.2}	130	20	11	210	1x100	55	-	105	27
NK9 - 310			180			310	2x100		52		
NK9 - 410			350			410	3x100		17		
NK9 - 510			450			510	4x100				
NK9 - 610			550			610	5x100				
NK9 - 710			650			710	6x100				
NK9 - 810			750			810	7x100				

FRICTIONLESS TABLES

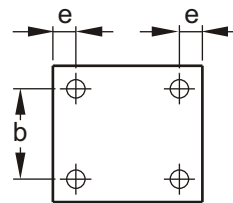
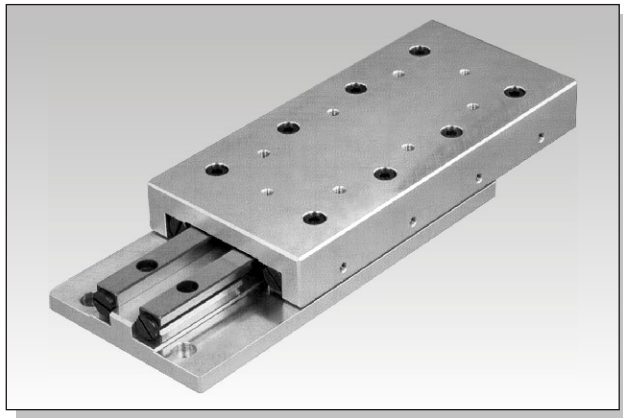

Fig-1

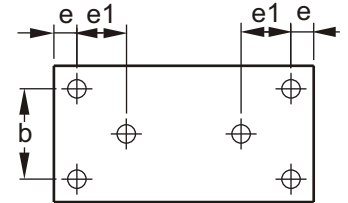

Fig-2

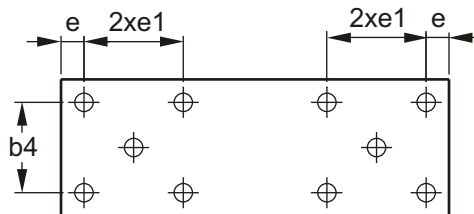

Fig-3

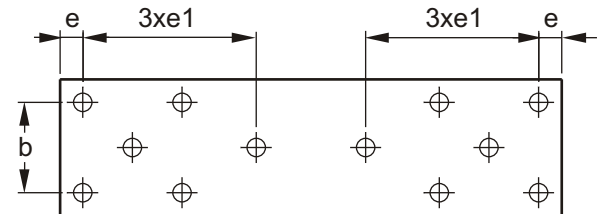
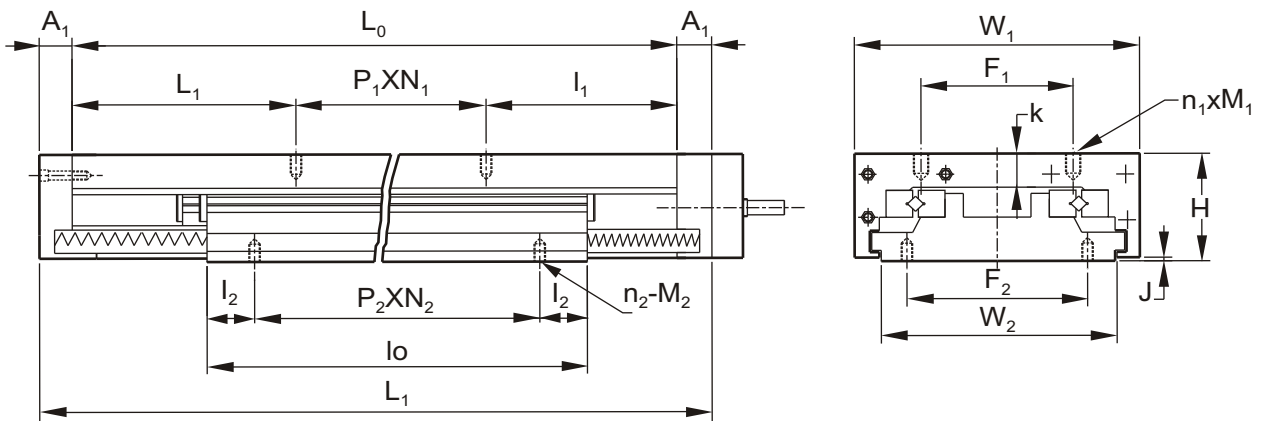

Fig-4

Layout of the standard mounting holes in the Base plate.

b	b1	b2	b3	b4	d	d2	d3	h	e	e1	Fig	Weight in Kg	C in kg	MI in kg	MQ in kg
-	40	25	39	40	M4	M3	M4	9	10	25	1	0.57	93	0.79	1.29
												0.8	133	1.19	1.85
												1.03	186	1.72	2.5
											2	1.26	225	2.12	3
												1.49	278	2.56	3.8
												1.72	327	3	4.4
3	1.95	357	3.4	5											
	60	92	50	64	60	M6	M6	13	50	50	1	3.07	378	5.83	8.5
												4.46	594	9.72	13
2											5.85	756	12.6	17	
											7.24	973	16.5	21	
3	8.63	1189	20	26											
	10.02	1351	23	30											
	11.41	1567	27	35											
	90	135	80	98	90	M8	M8	16	55	100	100	1	11.8	1193	29
17.3													1855	48	66
2												22.8	2120	55	76
												28.3	2518	66	90
3												33.8	3048	81	109
												39.3	3445	92	124
4	44.8	3976	107	143											

DUST PROOF SLIDE



Model No. and Stroke	Main Dimensions								
	Without Ball Screws		Lo	lo	W ₁	W ₂	H	J	K
	L ₁	A ₁							
DS3050	185	15	155	100	100	78	40	2	12
DS3075	260		230	150					
DS3100	340		310	200					
DS3125	415		385	250					
DS6050	200	20	160	100	150	118	60	20	
DS6100	350		310	200					
DS6150	500		460	300					
DS6200	660		620	400					
DS9100	360	25	310	200	200	160	80	3	25
DS9150	510		460	300					
DS9200	665		615	400					
Ds9300	970		920	600					

DUST PROOF SLIDE

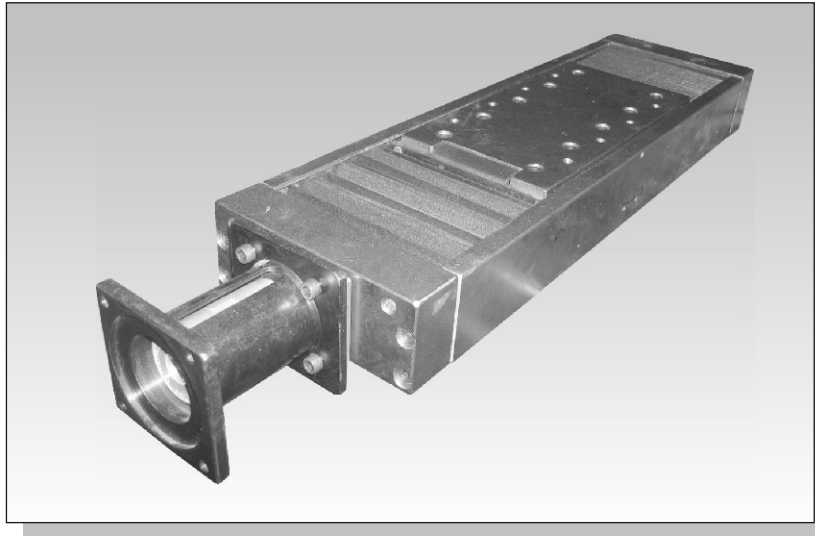

Dust Proof linear table consist of precision cross roller guides series R for smooth & precision movement. The top & bottom plates are made of low carbon steel/cast iron. The basic top plate construction & bellows make it extremely safe in adverse/stiff operating conditions. They are field proven & successfully working even in grinding applications.

Special features upon request such as

- Aluminium top & bottom for light weight.
- S.S. top & bottom for corrosive environment.
- Fitment of ball screws, pneumatic, hydraulic cylinder with respective drives.
- Surface finish Options : - blackodising, zinc plating, electroless nickel plating & powder coating etc.

Top Mounting Holes				Base Mounting Holes				Total Weight KgF
l_1	$P_1 \times N_1 \times F_1$	n_1	M_1	l_2	$P_2 \times N_2 \times F_2$	n_2	M_2	
52.5	50 x 1 x 50	4	M5	25	50 x 1 x 65	4	M5	4.1
65	50 x 2 x 50	6			50 x 2 x 65	6		5.7
80	50 x 3 x 50	8			50 x 3 x 65	8		7.4
92.5	50 x 4 x 50	10			50 x 4 x 65	10		9.1
30	50 x 2 x 80	6	M6	50	50 x 1 x 95	4	M6	10.2
105	50 x 2 x 80				50 x 2 x 95	6		17.6
130	50 x 4 x 80	10	M8	50	50 x 4 x 95	10	M8	25.1
160	50 x 6 x 80	14			50 x 6 x 95	14		32.8
80	50 x 3 x 100	8			100 x 1 x 130	4		31.6
155	50 x 3 x 100				100 x 2 x 130	6		44.4
182.5	50 x 5 x 100	12	100 x 3 x 130	8	58.4			
260	100 x 4 x 100	10	100 x 5 x 130	12	83.3			

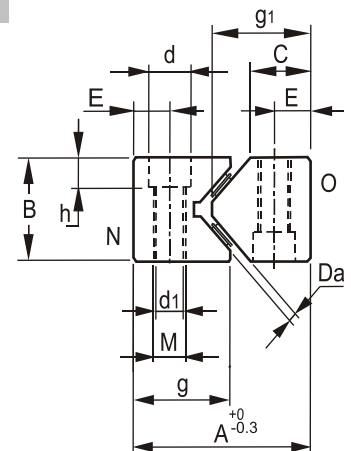
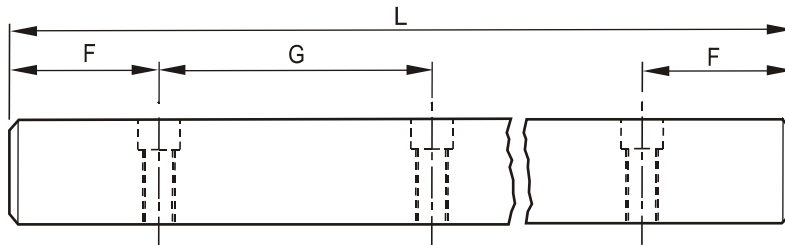
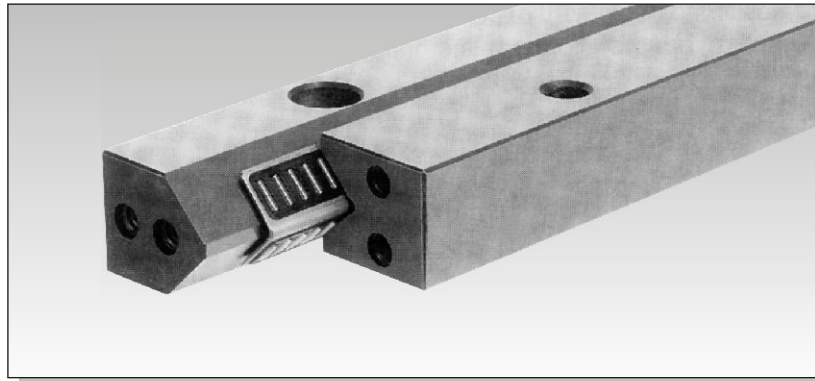

Needle roller guides type N/O

The guides are hardened (60-62 Hrc) and can be used with needle rollers in steel /plastic cages.

N/O guides are useful for accurate positioning and inspection systems.

These work both in horizontal & vertical application.

Features:

- High load carrying capacity.
- Low co-efficient of friction.
- Light and compact design.

One Set includes:

- 2 N rails
- 2 O rails
- 4 end pieces
- Plastic/steel cage needle roller bearing elements.

Bearing Number	Dimensions													
	Da	A	B	L	d	h	M	d1	F	G	E	g	g1	C
N/O 92025	2	44	22	200 300 400 500 600 700 800	10.5	6.2	M 8	6.8	50	100	9	24	24.5	15
N/O 2025		52	25	200 300 400 500 600 700 800 1000	13.5	8.2	M 10	8.5			10	28	29	18
N/O 2535	2.5	62	30	300 400 500 600 700 800 1000	16.5	10.2	M 12	10.5			12	34	35	22
N/O 3045	3	74	35	400 500 600 700 800 1000	18.5	12.2	M 14	12.5			14	42.5	40	25

Note : Longer lengths upon request.

SPINDLE UNITS

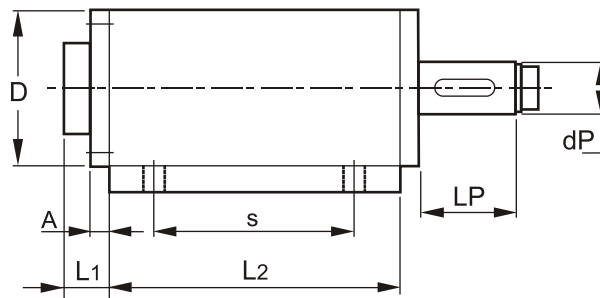
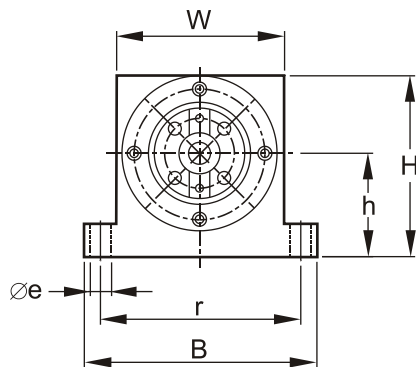
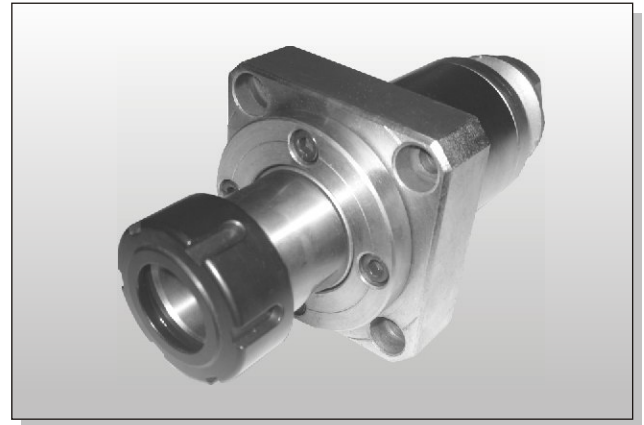
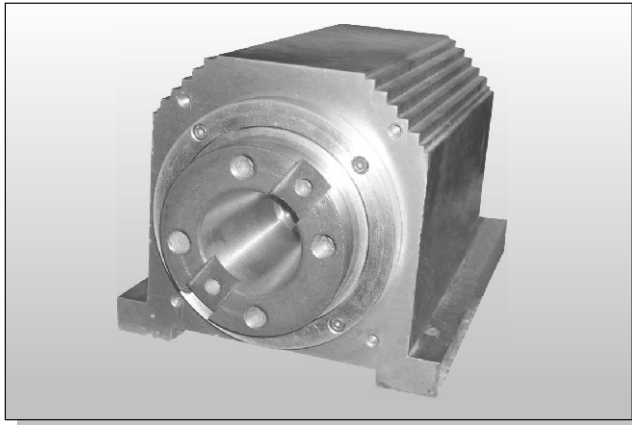

The spindles are manufactured with the intention of the requirements / demands of modern technology i.e. speed and accuracy. To meet this need of spindles it is drawing the experience of people who are working in machine tool industry for the last twenty years. The spindles are designed to meet specific requirements like running accuracies, rigidity and temperature.

The heart of spindle is shaft which is hardened, to impart strength in bending. The ends are machined to match machines like turning, milling, drilling boring etc. The housing is made of high quality cast iron which helps in reducing vibration and eases heat dissipation. Special care is taken for other parts machining with geometrical accuracy. The housing are cylindrical, flange type mounting, or rectangular base mounting.

Spindle Head No.	For Milling Nose Taper ISO	Dimensions												
		D	B	Lp	dp	A	h	H	L1	L2	W	r	s	øe
3	30	120	165	60	40	15	80	140	35	225	130	105	175	11
4	30/40	150	205	75	50	20	100	175	47	285	160	130	235	
5	40/50	180	250	110	70	20	125	215	50	350	200	170	300	13
6	50	230	290	125	90	20	160	275	56	420	250	210	370	
8	60	300	370	150	110	26	200	350	75	570	315	265	520	
11	60	380	495	200	150	40	250	440	95	690	400	340	640	

OPTIMA

CHAMFERING MACHINE

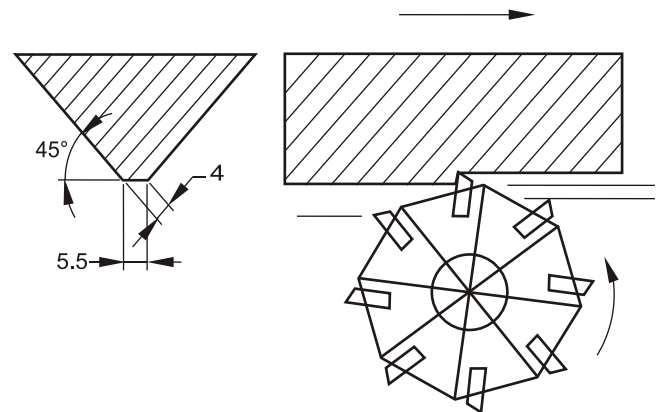

CHAMFERING AND DEBURRING MACHINES

Chamfering machines are rugged machines for use in the workshop for long periods under arduous conditions.

In contrast to the more traditional machines with aluminium casting, our machines have a solid non vibrating cast body.

The cutter head can be adjusted in an axial plane and this means that the cutter can be used over entire cutting width.

Quite running and the cutter head adjustment facility ensure an exceptionally long service life and chamfers which are clean and smooth. Wide guide rails in hardened steel make it possible for work piece which have been offered up and guided by hand to be chamfered and deburred very easily by cutter which has previously been set to the exact required depth.

Both work piece with a small cross sectional area of 50 x 20 mm or larger cross sectional area can be machined without difficulty.

TECHNICAL DATA

Chamfering height setting	:	0 - 4
Angle	:	45°
Axially adjustable cutter head	:	Dia 70x12 width
Motor	:	50HZ, 440V 0.77KW, 2800 RPM
Hardened guide rails	:	10x100x400
Size (l x b x h)	:	520 x 240 x 180 (approx)
Range of application	:	Aluminium, steel, cast iron Non ferrous metals, Plastic, wood, etc.

APPLICATION EXAMPLES

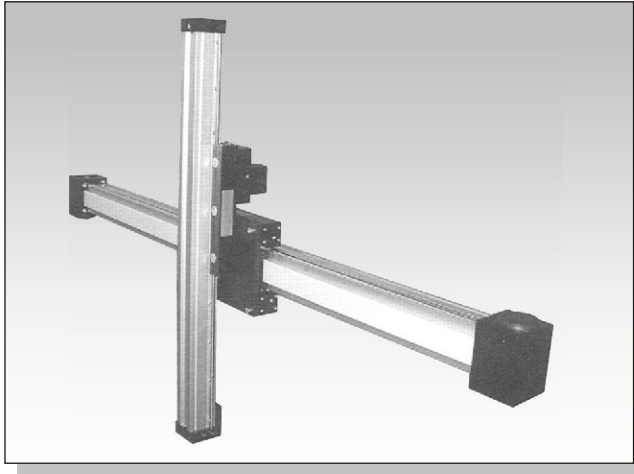

D

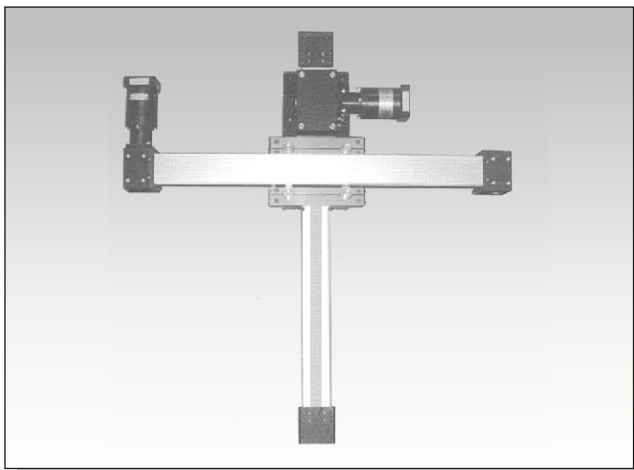
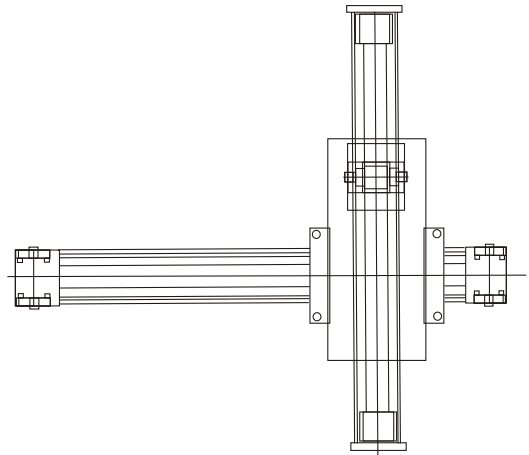

E

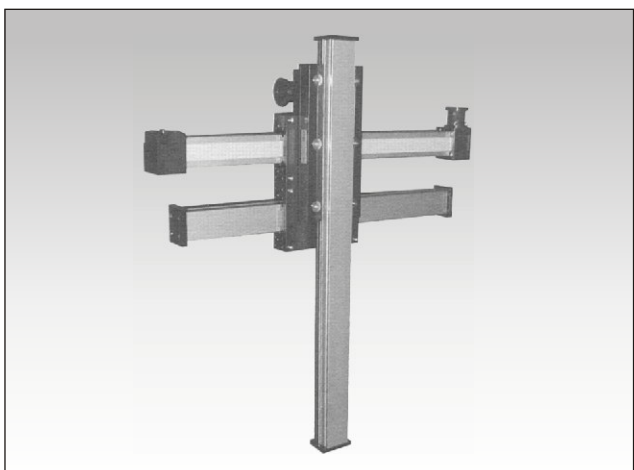
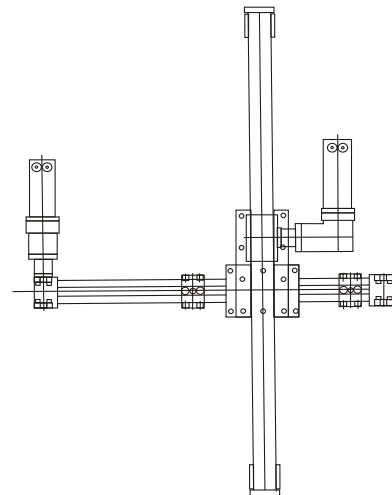

F

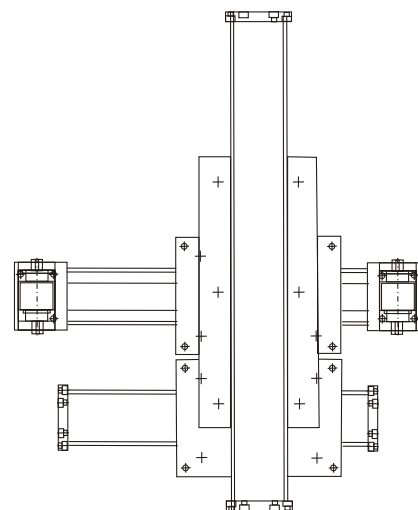

REQUEST FORM

Request for quotation

Customer Name Date :
..... Phone :
Address Fax :
..... Email :
..... Country :
..... Delivery Point:
..... Quantity :

Desired Delivery Date:

Type of Slide 1. Horizontal
 2. Vertical
 3. 3 Axis (X,Y,Z)

Required Specification

1. Slide Name
2. Load
3. Stroke
4. Application
 - i) Horizontal
 - ii) Vertical
 - iii) 3 Axis (X,Y,Z)
5. Speed
6. Motor Power
7. R.P.M.
8. Acceleration
9. Gear Box
10. Accuracy
11. V.F.D.

Customer special requirements



LFR 10 Internal

The image shows a linear guide assembly with a black motor housing on the right side. The motor is connected to a shaft that runs through the center of the guide rail. The rail is made of aluminum and has a T-shaped cross-section. The motor housing is rectangular and has a circular opening on the front face.



Track Roller Assembly

The image shows a linear guide assembly with a roller on the right side. The roller is made of metal and has a circular cross-section. The roller is mounted on a shaft that runs through the center of the guide rail. The rail is made of aluminum and has a T-shaped cross-section.



X Z Slide

The image shows a linear guide assembly with a roller on the right side. The roller is made of metal and has a circular cross-section. The roller is mounted on a shaft that runs through the center of the guide rail. The rail is made of aluminum and has a T-shaped cross-section. The assembly is shown in a perspective view, highlighting the X and Z axes.

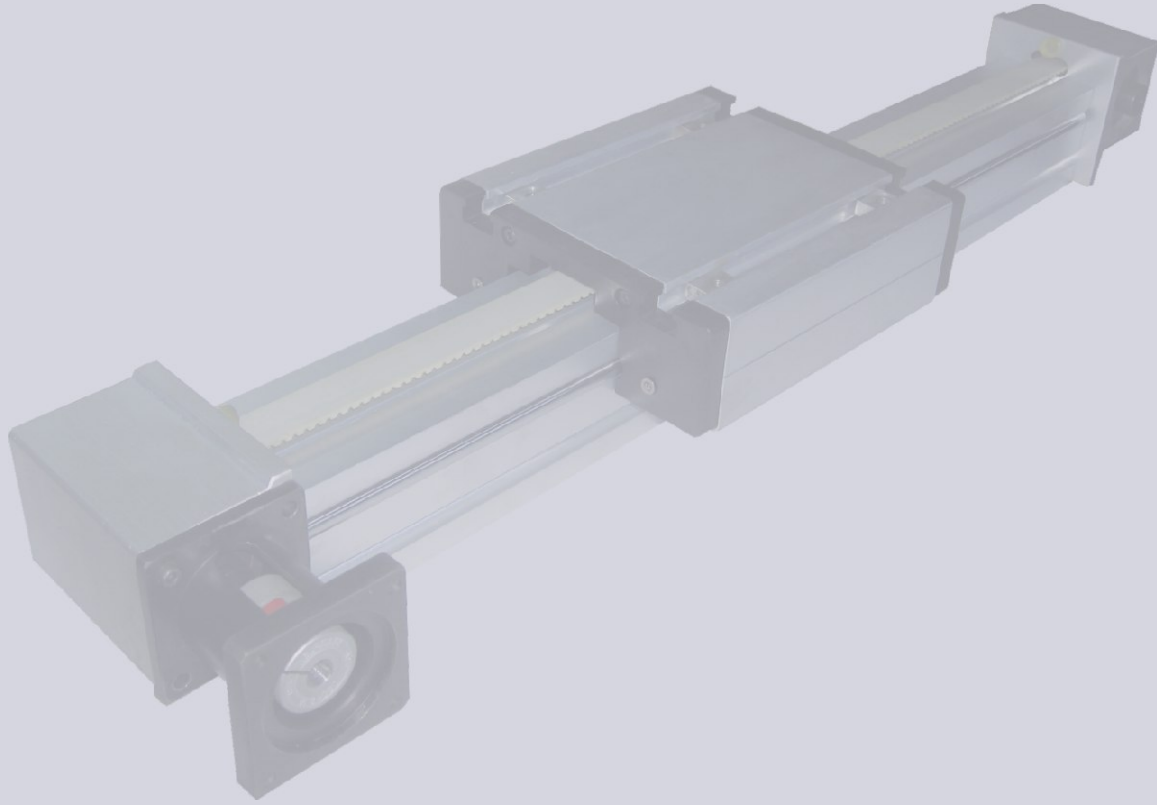

OPTIMA ENGINEERING SYSTEMS

26, Kartar Estate, L.B.S. Marg, Behind SBI,
Vikhroli (W), Mumbai 400 079. India
Tel: 91-22-6796 9750 Fax: 91-22-2579 5673
Email: sales@optimaengg.com

Due to continuous product development technical specifications
are subject to revision without prior notice.